



---

# Lennox GS Deregistration Analysis

Independent Electricity System  
Operator

---

**Issue 2.0**

*Final REPORT*

**Project:** Lennox GS Reliability Must Run Contract

**Period:** October 2008 to September 2009 and preliminary  
to December 2010

Transmission Assessments & Performance Department

September 15, 2008

Public

**REPORT**

## Disclaimer

The posting of documents on this Web site is done for the convenience of *market participants* and other interested visitors to the *IESO* Web site. Please be advised that, while the *IESO* attempts to have all posted documents conform to the original, changes can result from the original, including changes resulting from the programs used to format the documents for posting on the Web site as well as from the programs used by the viewer to download and read the documents. The *IESO* makes no representation or warranty, express or implied, that the documents on this Web site are exact reproductions of the original documents listed. In addition, the documents and information posted on this Web site are subject to change. The *IESO* may revise, withdraw or make final these materials at any time at its sole discretion without further notice. It is solely your responsibility to ensure that you are using up-to-date documents and information.

This document may contain a summary of a particular *market rule*. Where provided, the summary has been used because of the length of the *market rule* itself. The reader should be aware, however, that where a *market rule* is applicable, the obligation that needs to be met is as stated in the “Market Rules”. To the extent of any discrepancy or inconsistency between the provisions of a particular *market rule* and the summary, the provision of the *market rule* shall govern.

<b>Document ID</b>	IESO_REP_0516
<b>Document Name</b>	Lennox GS Deregistration Analysis
<b>Issue</b>	Issue 2.0
<b>Reason for Issue</b>	Support Lennox RMR for period Oct 2007 to September 2009 and preliminary to December 2010
<b>Effective Date</b>	September 15, 2008

## Document Change History

<b>Issue</b>	<b>Reason for Issue</b>	<b>Date</b>
1.0	Internal release - confidential	August 20, 2008
2.0	Public release	September 15, 2008

## Related Documents

<b>Document ID</b>	<b>Document Title</b>



# Table of Contents

---

<b>Table of Contents</b> .....	<b>i</b>
<b>List of Figures</b> .....	<b>ii</b>
<b>List of Tables</b> .....	<b>iii</b>
<b>Table of Changes</b> .....	<b>iv</b>
<b>1. Lennox Deregistration Analysis – summary</b> .....	<b>1</b>
<b>2. Conclusions and Recommendations</b> .....	<b>3</b>
2.1 Conclusions.....	3
2.2 Recommendation.....	3
<b>3. Introduction</b> .....	<b>4</b>
3.1 Purpose.....	4
3.2 Scope.....	4
<b>4. Major Assumptions</b> .....	<b>5</b>
<b>5. Operational data analysis</b> .....	<b>7</b>
5.1 General information.....	7
5.2 Capacity for Congestion Control – Interface FETT (Flow East To Toronto).....	8
5.3 Dynamic Voltage Control for GTA.....	9
5.4 Reliable supply to Ottawa.....	10
<b>6. Analysis of 2009 forecast</b> .....	<b>13</b>
6.1 Capacity to Control flows from the west on FETT (Flow East To Toronto) and Dynamic Voltage Control for GTA.....	13
6.2 Reliable supply to Ottawa.....	17
<b>Appendix A: Demand forecast</b> .....	<b>A-1</b>
<b>Appendix B: PSS/E model used for simulations</b> .....	<b>B-1</b>
<b>Appendix C: Dynamic simulation results</b> .....	<b>C-2</b>
<b>References</b> .....	<b>1</b>

# List of Figures

---

Figure 1: Ontario Zones, Interfaces and Interconnections .....	5
Figure 2: Pickering, Darlington and Lennox - output.....	7
Figure 3: FETT spare – Mar 16/07 to Jul 06/08.....	8
Figure 4: Lennox MW dependency on Toronto demand.....	9
Figure 5: Lennox reactive output as a function of Toronto demand .....	9
Figure 6: Ottawa demand from March 16, 2007 to July 10, 2008 .....	10
Figure 7: Ottawa zone demand compared with Ontario demand.....	10
Figure 8: Comparison of Ottawa and Toronto zones demand .....	11
Figure 9: FIO spare from March 16/07 to July 10/08 .....	11
Figure 10: Lennox reactive output vs. Ottawa demand - March 16, 2007 to July 10, 2008..	12
Figure 11: Flow South (FS) from March 16, 2007 to July 10, 2008.....	14
Figure 12: FETT 2009 forecast .....	15
Figure 13: FETT spare from June 2007 to July 2008 .....	16
Figure 14: FETT spare summer 2009 & 2010 based on 2007 & available 2008 data .....	16
Figure 15: FETT spare summer 2009 & 2010 based on 2007 data .....	17
Figure 16: Hawthorne 500 kV P-V curves - all elements in service.....	19
Figure 17: Hawthorne 500 kV P-V curve - L24A out of service .....	19
Figure 18: Hawthorne 500 kV P-V curve - L24A out of service, 150 MW L/R .....	20
Figure 19: Hawthorne 500 kV P-V curve - L24A out of service, 300 MW L/R .....	20
Figure 20: Ottawa demand forecast from Jul 01/08 to Dec 31/10 - duration .....	21
Figure 21: Ottawa demand forecast from Jul 01/08 to Dec 31/10 - duration .....	21
Figure 22: Ottawa - January 22, 2010 .....	22
Figure 23: Hawthorne 500 kV bus voltage post X522A and L24A contingencies with and without Lennox.....	C-2
Figure 24: Hawthorne 220 kV bus voltage post X522A and L24A contingencies with and without Lennox.....	C-2

## List of Tables

---

Table 1: Major generation availability: .....	7
Table 2: Load and Generation comparison West vs. East of FETT .....	8
Table 3: FETT - replacing Lennox with Portlands and Goreway .....	15
Table 4: Post X522A contingency voltage deviation comparison .....	18
Table 5: Load rejection availability in Ottawa zone .....	20
Table 6: Hours exceeding the 5% post-contingency criterion .....	21
Table 7: Zonal demand forecast from January 2008 to December 2009 – extreme weather, firm resource scenario per the latest 18-month outlook. ....	A-1
Table 8 : Summer 2009 extreme weather demand, Lennox I/S, Goreway and Portlands O/S .....	B-1
Table 9: Summer 2009 extreme weather demand, Lennox O/S, Goreway and Portlands I/S .....	B-1

# Table of Changes

---

<b>Reference (Section and Paragraph)</b>	<b>Description of Change</b>

# 1. Lennox Deregistration Analysis – summary

---

Ontario Power Generation (OPG) has requested that operation of Lennox Thermal Generation Station (TGS) be discontinued and that all generation facilities at Lennox be de-registered by October 1, 2008, for economic reasons. This study covers the October 2008 to September 2009 period and preliminary to December 2010 and was performed to identify the impact of deregistering Lennox TGS units on the reliability of the IESO-controlled grid to:

- Accommodate expected peak flows to the Ottawa area,
- Accommodate expected peak flows towards Toronto from the west,
- Provide sufficient reactive resources and adequately control voltages in the Greater Toronto area, and eastern Ontario including the Ottawa area.

Lennox TGS is geographically located near Kingston, Ontario and represents over 50% of the total generation capacity in the East<sup>1</sup> zone - 2200MW out of 4396MW. Lennox TGS's electrical location provides a variety of benefits to the IESO Controlled Grid:

- Generation capacity on the load side of the congested transmission lines converging from the west towards Toronto (interface FETT – Flow East To Toronto).
- Dynamic voltage control for the GTA, eastern Ontario in general, and specifically the Ottawa area.
- Reliable supply to the Ottawa area.

Two previous Lennox deregistration studies indicated that currently the Ontario system requires all four Lennox units for reliable supply of GTA and Ottawa under forecast conditions. It should be noted that no significant changes are expected during the first seven months (October 2008 to April 2009) of the following term so the requirement for all Lennox units remains unchanged. Starting spring 2009 three major projects: Goreway Station and Portlands Energy Center combined cycle operation in GTA and the Quebec HVDC connection are entering commercial operation which significantly reduces the system reliance on Lennox units for GTA and Ottawa local reliability support. This study shows that some Lennox support may still be needed during summer 2009. It is recommended to contract all four Lennox units until September 30, 2009 in case there's any delay in commissioning the new facilities and until sufficient experience and data accumulates to confirm that supply reliability does not suffer if some Lennox units are deregistered. At the present time, under the firm resources scenario and demand forecast, insufficient justification was found for extending the Lennox RMR contract beyond September 2009. If there is a material change in the load forecast or the expected resource availability, this decision will be reviewed.

The combined data from January 1, 2005 to March 15, 2007 used for the previous analysis indicated that Lennox units were in service, supporting system reliability for 4495 hours, (23% of the time) with the plant at full capacity (4 units) for about 717 hours (almost 4% of the time). Data from March

---

<sup>1</sup> East zone - as defined by the ten zone model of the Ontario system (see Figure 1).

16, 2007 to July 10, 2008 shows that Lennox units were in service for about 2688 hours (23% of the time), with four units in service for 113 hours (1% of the time).

This current analysis considered the demand forecast, availability of hydro-electric generation and outage plans registered with the IESO to date, as published on the Q2-2008 18 Month Outlook and a preliminary forecast for the Ottawa zone ending December 31, 2010. The results show that all 4 units at Lennox are required for the purposes of reliability during the period Oct 2008 to Apr 2009. The new generation capacities at Goreway Station and Portlands Energy Center, scheduled to go in service in spring 2009, are expected to significantly reduce the requirement for Lennox to control flows from the west towards Toronto. The Hawthorne to Quebec DC connection can be used to control the flows into the Ottawa area but when not delivering energy it does not offer the same voltage control capability in eastern Ontario as effectively as Lennox. It should be noted that under reliability must run contract Lennox generation capacity is available when needed to control eastern Ontario voltages and support high flows into Ottawa, while presently the planned resource scenario does not rely on imports to satisfy internal reliability requirements.

Under the current limit structure, the transfer capability to the Ottawa area is dependent on the number of Lennox units in service. More than two units are required to realize additional benefits by arming local load rejection. Extreme weather conditions in the Ottawa area can result in an FIO (Flow Into Ottawa) as high as 1950MW and under certain outage conditions may require all four Lennox units and at least 150 MW of load rejection armed in Ottawa to reliably supply the zone. The operating documents currently in force only allow load rejection in Ottawa to be armed if Lennox units are synchronized to the grid. A review of these operating limits to recognize the new connection to Quebec and its associated facilities is expected to result in an improvement in the transfer limit and the effectiveness of allow arming of load rejection in Ottawa when all Lennox units are disconnected from the grid. As a result, Lennox support may no longer be required beyond September 2009 to reliably supply the Ottawa zone if sufficient load rejection can be armed.

**– End of Section –**

## 2. Conclusions and Recommendations

---

### 2.1 Conclusions

From March 16, 2007 to July 10, 2008 Lennox units operated for 2688 hours (23% of the time), with all four units in service for 113 hours (1% of the time). During this time the plant supplied around 949 GWh of electricity to the Ontario grid.

The data shows that Lennox units supported the FETT for 228 (2% of the time). During this period all four units were required for FETT control for about 8 hours (0.1% of the time). This happened in a period of fairly mild summer weather when Toronto zone demand didn't reach the highest possible peak. Previous years experience shows that Lennox support becomes more critical as the weather approaches extreme. The new generation capacities at Goreway Station and Portlands Energy Center, scheduled to go in service in spring 2009, are expected to substantially reduce the requirement for Lennox to control flows from the west towards Toronto, but their combined capacity (1425 MW) does not completely replace the Lennox capacity.

The Lennox units are providing key support for improving the transfer capability to reliably supply the Ottawa zone. Without Lennox support about 250 MW (at maximum) of pre-contingency load reduction would have been required in the Ottawa zone for up to 54 hours in the period March 16/2007 to July 10/2008.

The transmission enhancements associated with new tie and HVDC connection with Transenergie expected to go in service in spring 2009 is expected to reduce reliance on Lennox for Ottawa supply. The last five months of the new term will provide useful information to understand how much support the Ottawa area gets from the new facilities in real time operations.

### 2.2 Recommendation

It is recommended to contract all four Lennox units from October 2008 to September 2009. During the first seven months Lennox is expected to play the same role as before. The last five months cover summer 2009 with potential high demand periods in Toronto and Ottawa and September with its possible lower demands but traditionally a higher number of planned outages scheduled. Allowing for this RMR to overlap the planned in-service date of the new facilities will insure against potential delays and to confirm their reliable operation which is consistent with the IESO principle of ensuring new facilities are operationally robust before existing facilities are potentially replaced. Under the current firm resource scenarios and demand forecast, insufficient justification was found for extending the Lennox RMR contract beyond September 2009. If there is a material change in the load forecast or the expected resource availability, this decision will be reviewed.

– End of Section –

## 3. Introduction

---

### 3.1 Purpose

This study was performed to identify the impact of retiring Lennox TGS units on the reliability of the IESO-controlled grid to:

- Accommodate expected peak flows to the Ottawa area,
- Accommodate expected peak flows towards Toronto from the west,
- Provide sufficient reactive resources and adequately control voltages in the Greater Toronto area, and eastern Ontario including the Ottawa area.

### 3.2 Scope

The study assessed the need and identified the benefits of retaining Lennox GS for the period October 2008 to September 2009 and based on preliminary data up to the end of December 2010. This document outlines the technical considerations of this study, the benefits of Lennox TGS for the local area reliability, for reducing the congestion of FETT (Flow East To Toronto) and the role of Lennox GS in providing reactive support and reliable supply to the Ottawa zone loads.

The study also provides a detailed analysis of operational data from March 16, 2007 to July 10, 2008.

– End of Section –

# 4. Major Assumptions

This study covers the period October 2008 to September 2009 and preliminary up to December 2010, and assessed the following conditions:

- Extreme weather demand forecast for summer 2009, as published in the latest 18 Month Outlook, preliminary forecast for Ottawa zone to the end of 2010;
- All existing and committed generation and transmission projects in service.
- Generator outage plans as registered with the IESO to date.
- Hydro-electric generation availability forecast as per the latest IESO 18-Month Outlook.
- Typical FETT limit of 4900 MW during the summer (to account for transmission outages)

Operation of the IESO-controlled grid is illustrated by the ten-zone model shown in Figure 1 below (Ontario Zones, Interfaces and Interconnections).

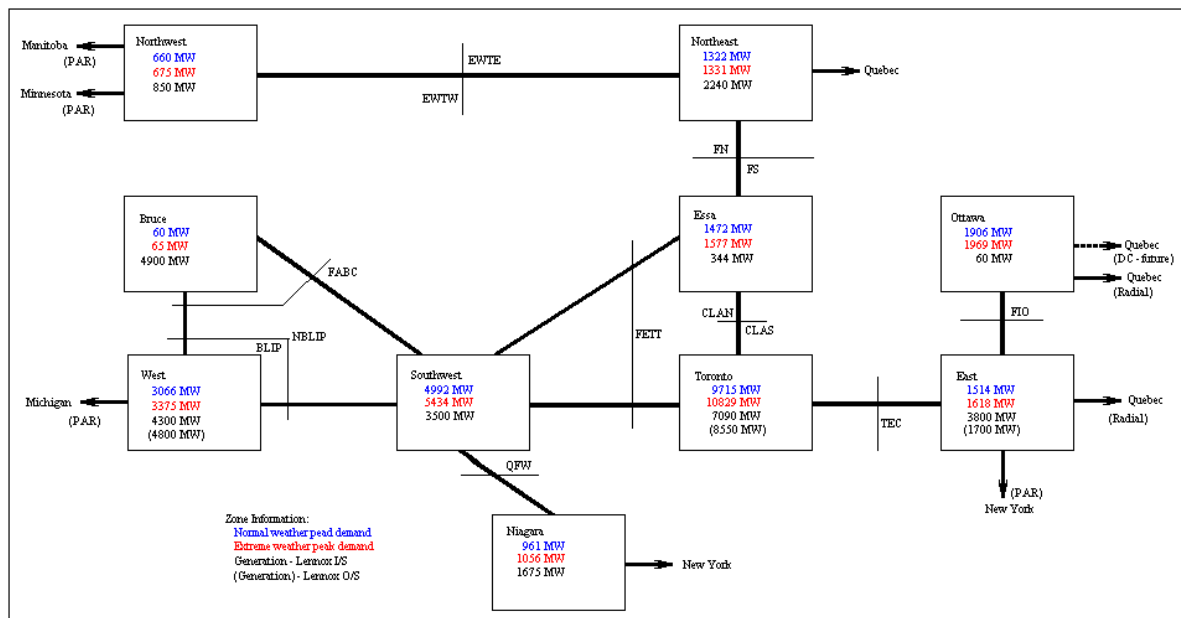

Figure 1: Ontario Zones, Interfaces and Interconnections<sup>2</sup>

This analysis was performed to determine the impact of de-registering Lennox units on the transfer limits of the FETT and FIO interfaces. The simulations were performed for the summer peak extreme weather demand forecast, with zero imports into Eastern Ontario from Quebec and zero flow at St. Lawrence. The results of these simulations were compared against pre and post contingency limits of the FETT and FIO interfaces. With all elements in service the pre-contingency flows were checked against continuous ratings and grid transfer limits; post-contingency flows were checked against long-

<sup>2</sup> Generation values are based on the most likely dispatch for summer 2009 extreme weather peak demand.

time emergency ratings. With one element out of service the pre-contingency flows were checked against long-time emergency ratings.

Under the current limit structure the FIO limit can be improved by 150 MW if two Lennox units are in service. Subsequently, the FIO limit may be further improved by another 150 MW if the remaining two Lennox units are in service and an equivalent amount of load rejection is armed in Ottawa. It is to be noted that under the current limit structure load rejection in Ottawa helps improve the FIO limit only if more than two Lennox units are in service. This limit improvement can provide a safe margin while transmission elements are taken out of service for maintenance.

**– End of Section –**

# 5. Operational data analysis

## 5.1 General information

The previous Lennox de-registration analysis looked at the data starting January 01, 2005 to March 15, 2007. This study collected information from March 16, 2007 to July 10, 2008 following the same rationale as the previous studies.

The generation availability of the main units located east of FETT is summarized below:

**Table 1: Major generation availability:**

Number of units	Number of hours					
	Lennox	%	Pickering	%	Darlington	%
1	2010	17.3%	0	0.0%	0	0.0%
2	382	3.3%	244	2.1%	0	0.0%
3	183	1.6%	1936	16.7%	437	3.8%
4	113	1.0%	3942	34.0%	11153	96.2%
5	N/A	N/A	3171	27.4%	N/A	N/A
6	N/A	N/A	2229	19.8%	N/A	N/A
Total	2688	23.0%	11592	100.0%	11592	100.0%

Total hours = 11592

During this time period the Ontario demand exceeded 20000 MW for 1381 hours representing 11.9% of the time. Lennox units were in service for 1090 of these hours, which would represent 30.6% of the total number of hours Lennox units were in service. The rest of the time Lennox operated while the Ontario demand was below 20000 MW indicating that the unit’s support is not only required during high demand but during a vast variety of operating conditions::

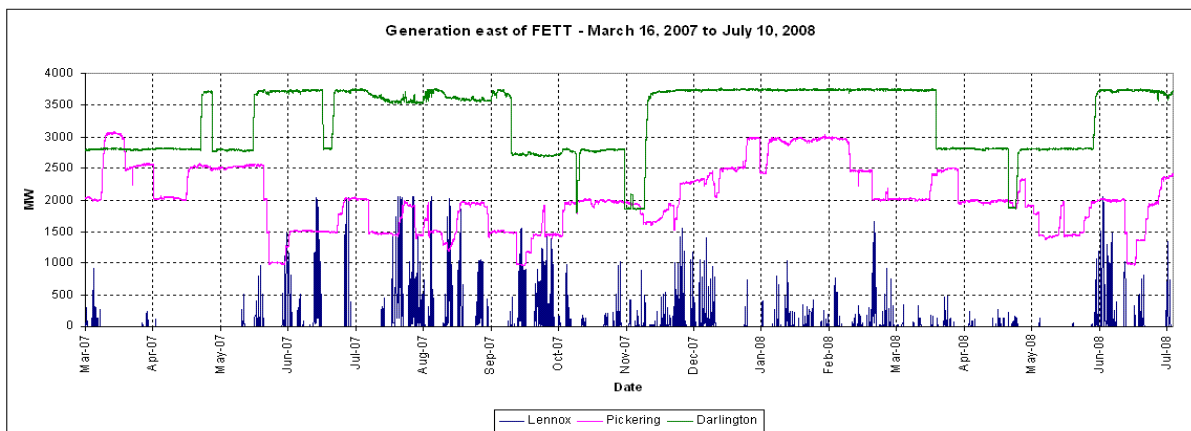

**Figure 2: Pickering, Darlington and Lennox - output**

The support of Lennox units was required during all seasons to maintain the grid’s reliability when units at Pickering, Darlington or transmission elements were taken out of service for maintenance.

## 5.2 Capacity for Congestion Control – Interface FETT (Flow East To Toronto)

Figure 1 shows that from the transmission system perspective interface FETT is connecting two major regions of the province: First region located west of FETT contains 36% of the load and about 50% of the existing generation. This region also connects to Ontario's main external energy sources in Michigan and New York. The second region, situated east of FETT has 64% of the total province load and 50% of the generation. The previous Lennox de-registration analysis indicated that northern hydro-electric generation contribution (reflected in the Flow South level) decreases over consecutive high demand days due to increasingly reduced water levels. This can change the balance of generation east vs. west of FETT by about 400 to 500 MW. Another problem that directly impacts FETT flow is that Pickering over the last few summers had at least one unit unavailable for extended periods. As a result, the available generation east of FETT can at any time be almost 1000 MW lower than Figure 1 shows. The following table compares generation and load in these two regions under different assumptions, with Lennox in service (current situation), with Lennox out of service (and partially replaced by Goreway Station and Portlands Energy Center – summer 2009) and this last scenario for low Flow South and one Pickering out of service.

**Table 2: Load and Generation comparison West vs. East of FETT**

(MW)	West of FETT			East of FETT		
	Demand	Generation	Load/Generation	Demand	Generation	Load/Generation
With Lennox	9930	14375	69%	17999	14384	125%
Without Lennox	9930	14875	67%	17999	13744	131%
Low Pickering and FS	9930	15875	63%	17999	12744	141%

The balance of power changes in such a way that FETT flow increases. The following figure compares the FETT spare capacity, calculated as limit minus flow and the same quantity adjusted to discount Lennox output and imports from Quebec and St. Lawrence. The adjusted spare capacity goes negative for 228 hours indicating that without Lennox generation (and imports) east of FETT, load reduction measures in GTA may have been required to control the flows:

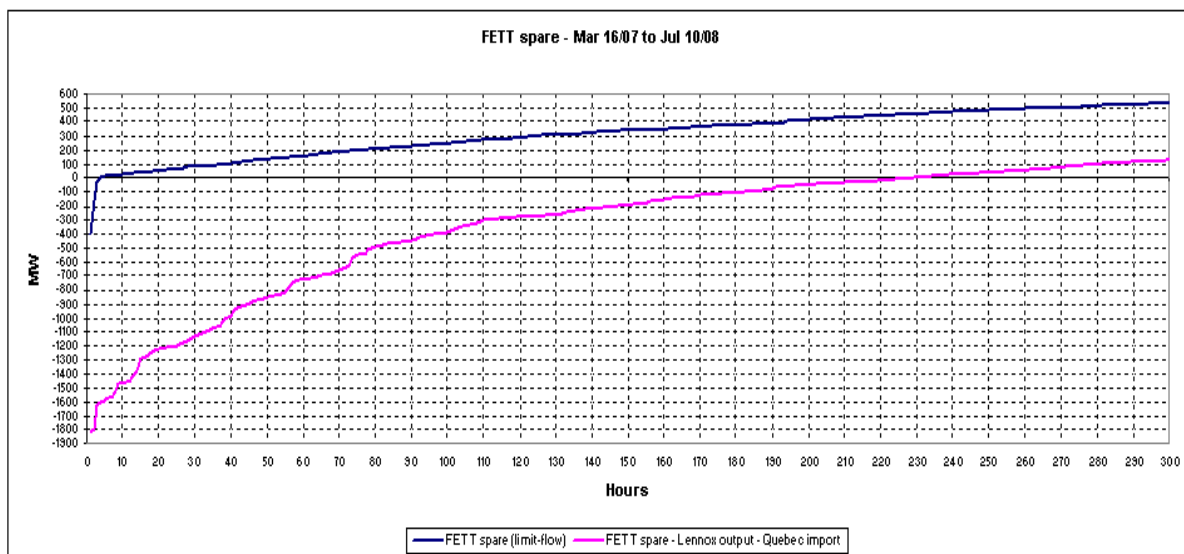

**Figure 3: FETT spare – Mar 16/07 to Jul 06/08**

Previous assessments show that Lennox support was required mostly during the warm season when the demand is high mainly due to air conditioner load in southern Ontario. The data from March 16, 2007 to July 10, 2008 also confirms that Lennox was used when Toronto demand was high, especially in the above 8000 – 9000 MW range:

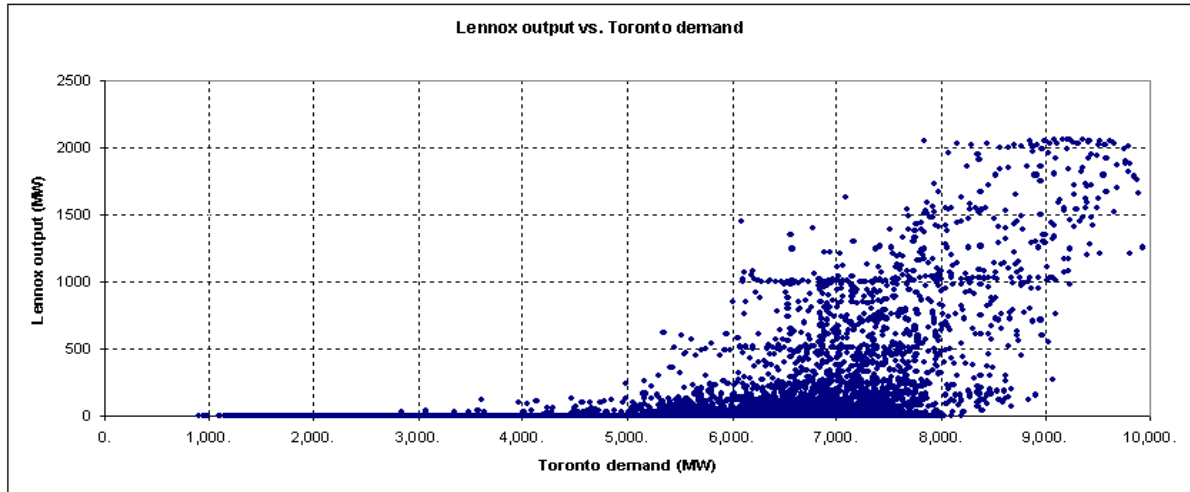
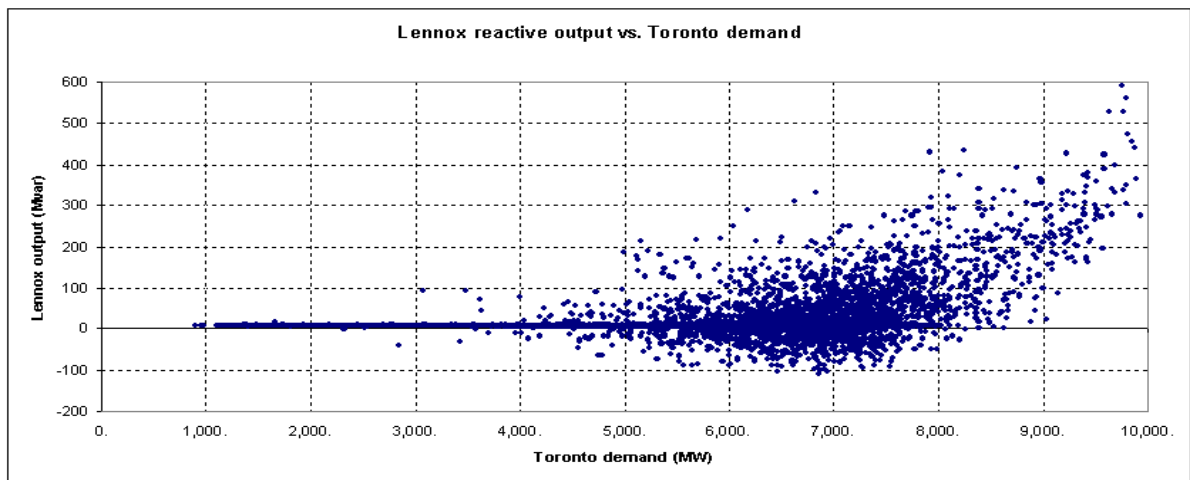

**Figure 4: Lennox MW dependency on Toronto demand**

During this period Toronto zone demand exceeded 9000 MW for 92 hours. The reliance on Lennox for Toronto supply is quite obvious taking into consideration that summer 2007 was fairly mild.

### 5.3 Dynamic Voltage Control for GTA

The high demand period also requires most of the reactive support that generators can provide. Analysis of the new data shows that Lennox support was required for a demand range in the Toronto zone starting at about 5000 MW and going up to the maximum. The capacity of all units was required for demand higher than 9000 MW:



**Figure 5: Lennox reactive output as a function of Toronto demand**

The reactive support from Goreway Station and Portlands Energy Center will be provided, from a transmission system perspective, right where it's needed. In the event that there are material changes to the expected in service dates or availability of these new facilities, or to forecast demand or other material factors, the need for Lennox will be reviewed in early 2009.

## 5.4 Reliable supply to Ottawa

Lennox units also assisted in maintaining a reliable supply to Ottawa. The generation is effective in controlling and maintaining voltage for the Ottawa area loads during high demand periods or if transmission elements are out of service for maintenance.

For the second year in a row Ottawa reached the highest peak in summer (2007 & 2008) instead of winter (2007-2008).

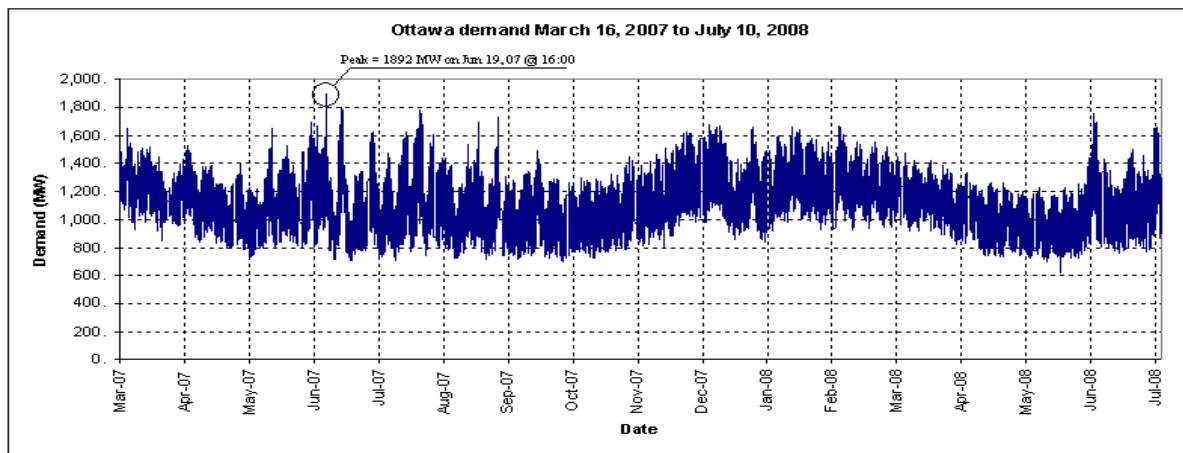

**Figure 6: Ottawa demand from March 16, 2007 to July 10, 2008**

Due to the nature of the loads causing the peak (air conditioners in summer versus lights and heating in winter) high summer demands require more reactive support. Figure 6 also shows that daily demand variations in summer are significantly more dynamic than winter.

Ottawa demand, over this period aligns quite well with the Ontario demand, which is known to be highly correlated to the demand profile of southern Ontario:

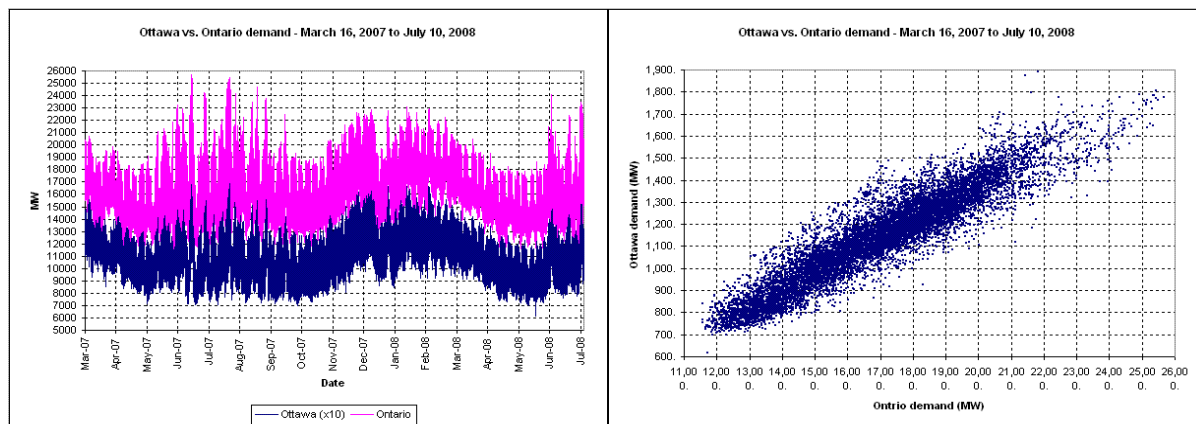

**Figure 7: Ottawa zone demand compared with Ontario demand**

Ottawa demand represents anywhere between a minimum of 5% up to maximum 8% of total Ontario demand, too small to influence the overall profile. Figure 7 left shows how Ottawa profile (magnified 10 times for better visibility) follows closely the Ontario demand. The right graph shows Ottawa correlation with Ontario demand, confirming that within certain limits Ottawa behaved very similar with southern Ontario.

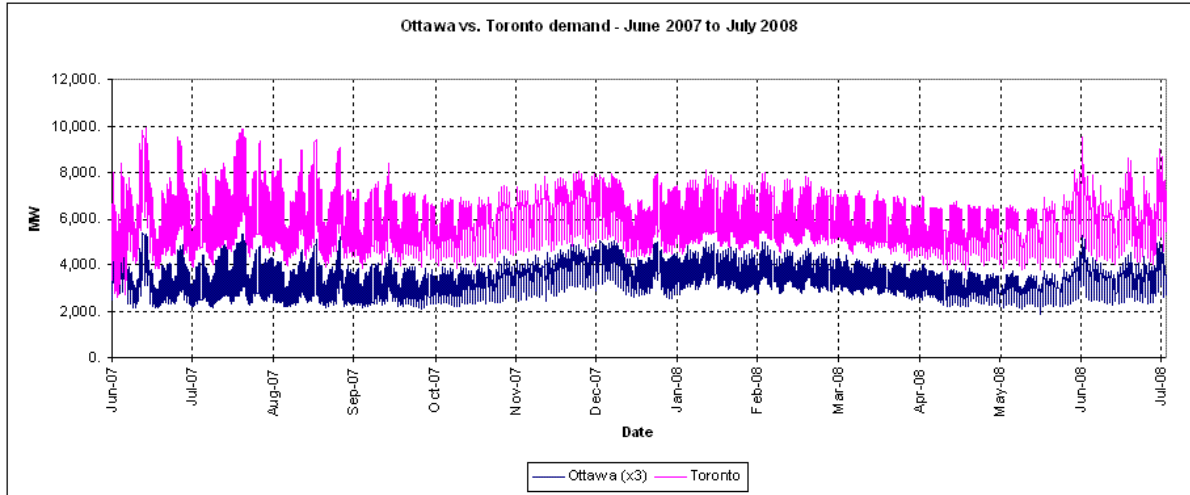

**Figure 8: Comparison of Ottawa and Toronto zones demand**

Further on, figure 8 shows how Ottawa (scaled up three times for clarity) compares against Toronto zone demand from Jun 2007 to July 2008. This shows that basically both zones (local areas) may have required Lennox support almost simultaneously.

From March 16, 2007 to July 10, 2008 the Flow into Ottawa (FIO) required Lennox support for up to four units for 54 hours:

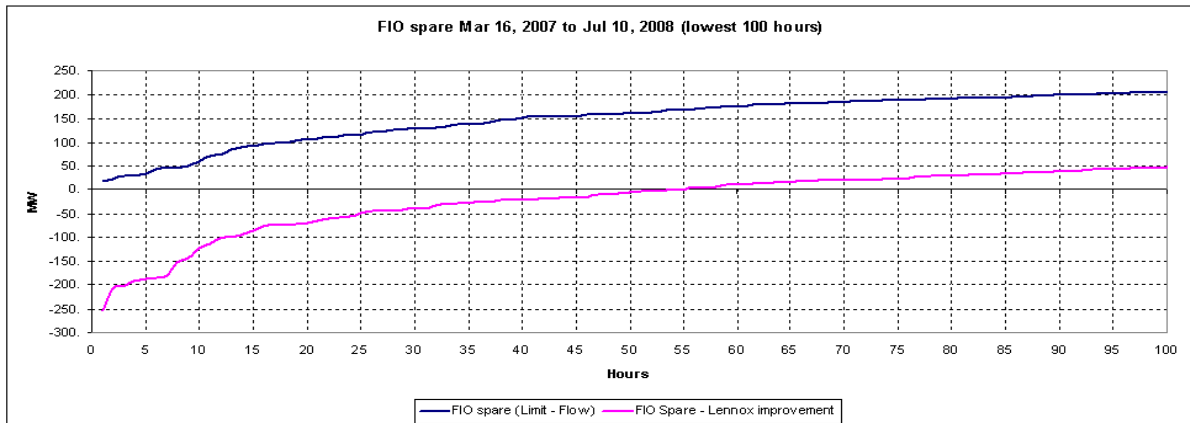

**Figure 9: FIO spare from March 16/07 to July 10/08**

The graph shows that without the Lennox improvement the FIO transfer limit would have been exceeded for up to 54 hours and may have required load reduction measures to be implemented.

The reactive support from Lennox was also required during high demand periods in Ottawa:

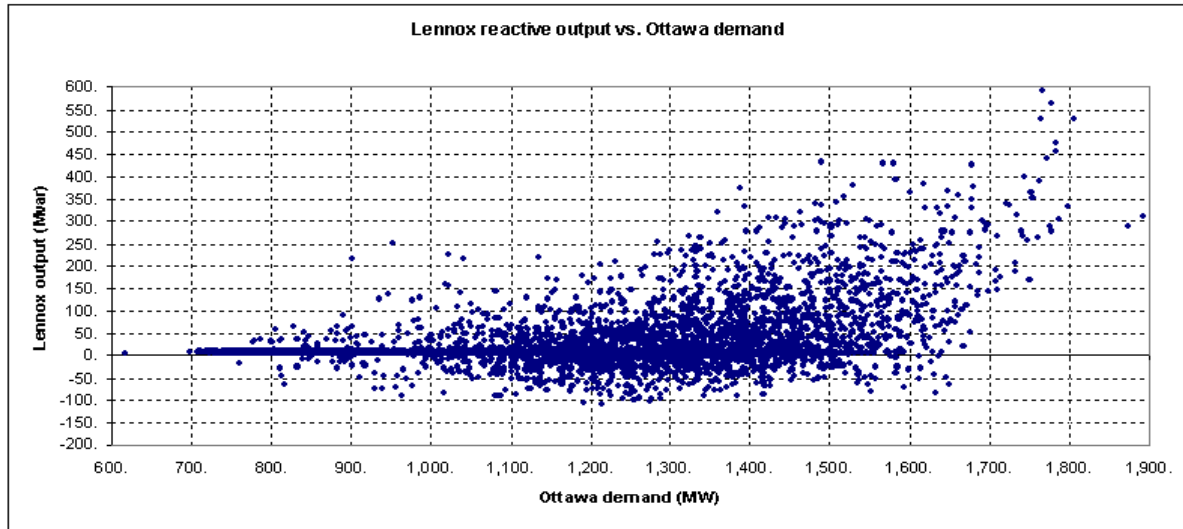

**Figure 10: Lennox reactive output vs. Ottawa demand - March 16, 2007 to July 10, 2008**

Without Lennox support up to more than 250 MW (at maximum) of load reduction may have been required in Ottawa zone.

**– End of Section –**

## 6. Analysis of 2009 forecast

---

To identify the future need for Lennox TGS during the period October 2008 to September 2009 and potentially up to the end of 2010, this section reviews the most significant factors affecting the reliability need for Lennox to:

- Accommodate expected peak flows to the Ottawa area (Reliable Supply to Ottawa);
- Accommodate expected peak flows towards Toronto from the west over the FETT (Flow East To Toronto) interface;
- Provide sufficient reactive resources and adequately control voltages in the Greater Toronto area, and eastern Ontario including the Ottawa area.

These factors are:

- Extreme weather peak demand forecast for the study period;
- Hydro-electric capacity and energy availability for the study period;
- Availability of major generators east of Toronto, including Pickering, Darlington, and Lennox;
- Imports into Ontario.

Some of these aspects were mostly covered in Part 5 – Operational data analysis and the previous Lennox TGS deregistration analysis for the period October 2006 to September 2007 and October 2007 to September 2008. The analysis of 2009 and preliminary 2010 forecast focused on expected changes over the current study period.

### 6.1 Capacity to Control flows from the west on FETT (Flow East To Toronto) and Dynamic Voltage Control for GTA

The previous Lennox GS deregistration analysis (October 2007 to September 2008), indicated that all four Lennox units were required to reduce the congestion over the transmission interface located west of the GTA and ensure reliable supply for Toronto area which was subsequently confirmed during operations.

A comparison of the major factors in the previous and present report reveals:

The latest forecast for 2008 indicates an extreme weather demand of 10829 MW for the Toronto zone, which represents an increase of 157 MW above the demand forecast of 10762 MW used in the previous Lennox analysis. The total Ontario demand for 2009 is forecast to go as high as 27930 MW under extreme weather conditions, which represents a 106 MW increase over the similar 2008 forecast (27824 MW).

There are no transmission reinforcements scheduled for the FETT interface over this study period so the increase in forecast demand in the Toronto area will increase the requirements for MW flow into the area, and increase the need for voltage control in the area; both factors will require increased

reliance on Lennox. During the first seven months of the following term no changes that can affect the results of previous studies are expected. The coming in service of Goreway Station and Portlands Energy Center will replace almost 68% of Lennox over the last five months of the period and beyond, but the difference should still come through FETT.

Northern hydro-electric generation helps reducing FETT. The previous analysis showed that due to reduced water levels its contribution decreases towards the end of the summer. The current data shows the same tendency:

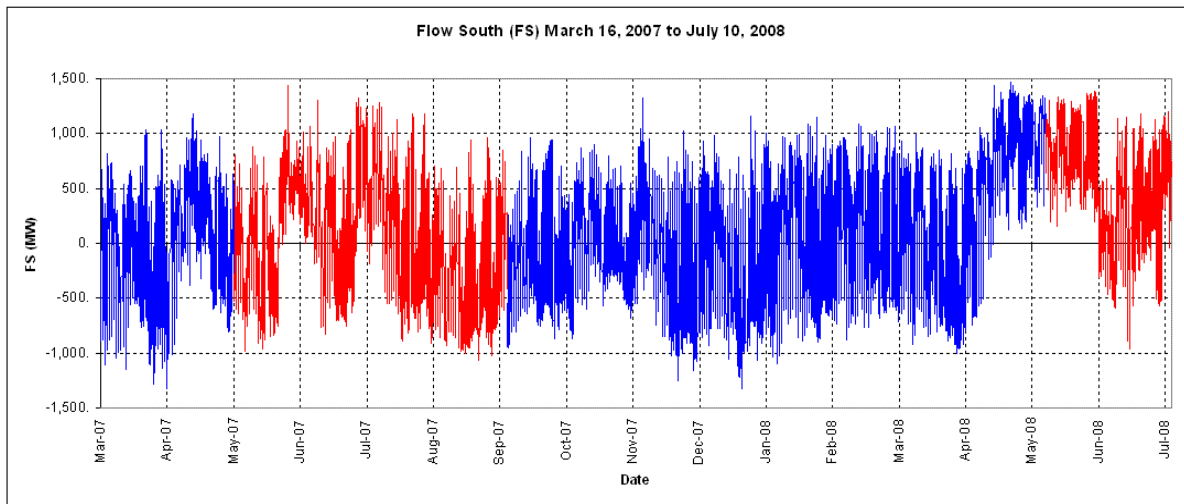

**Figure 11: Flow South (FS) from March 16, 2007 to July 10, 2008**

All previous studies assumed a Flow South value of about 1000 MW based on the hydro electric forecast. Historical data analysis shows that this can be achieved for short periods of time and if required on consecutive days a number in the order of 500 to 700 MW can be counted on for the second or third day of a potential heat wave. The experience also shows that demand tends to increase during the second and third day of a heat wave. This reduction of hydro-electric output in combination with increased demand may call for more Lennox support to control FETT.

As of now, there are no planned outages of Pickering units planned for summer 2009. Historical data analysis indicates that at least one Pickering unit was out of service at any time during the summer indicating there's a fairly high possibility to have one Pickering unit out in summer 2009 too.

The new generation east of FETT scheduled to go in service about half way through the current study period:

- Goreway Station – 875 MW, expected in service March 2009
- Portlands Energy Center – 550 MW, expected in service June 2009

are adding 1425 MW to the Toronto zone (east of FETT). This falls about 650 MW short compared to the total Lennox output, so this difference must come from west of FETT where the new capacities at Greenfield Energy Center and St. Clair Energy Center will be up and operational.

The following simulation results shows how FETT and component circuits flow may change due to this difference in output:

**Table 3: FETT - replacing Lennox with Portlands and Goreway**

Interface	Lennox I/S (MW)	Lennox O/S (MW)	Change (MW)	Change (%)
<b>FETT</b>	<b>3875</b>	<b>4471</b>	<b>596</b>	<b>15%</b>
- M570V	319	477	158	50%
- M571V	319	477	158	50%
- V586M	569	704	135	24%
- B560V	1090	1184	94	9%
- E8V	37	60	23	63%
- E9V	37	60	23	63%
- R14T	392	401	9	2%
- R17T	392	401	9	2%
- R19T	359	352	-7	-2%
- R21T	362	355	-7	-2%

The main benefit of the new plants consists in their location: by generating inside GTA, instead of more than 200 km east of GTA as Lennox does, they're reducing the transmission losses in and around the Toronto zone. The calculated losses in the Toronto zone only, under these specified conditions, are 142 MW with Lennox and 135 MW with Goreway Station and Portlands Energy Center in service. In this particular example, because the energy difference has to travel over a more congested area, the overall system losses are increasing from 810 MW with Lennox in service to 840 MW with Lennox out of service (and Portlands Energy Center and Goreway Station in service).

To properly determine the impact of this capacity difference the data from June 2007 to July 2008 was revised to incorporate the following changes:

- FETT was proportionally increased with the forecast Toronto demand (only), considering that summer 2009 will be similar to 2007;
- Portlands Energy Center and Goreway Station (P&G) are available at any time, their output represents a MW for MW FETT reduction;
- Zero imports from Quebec (all circuits) and New York (at St. Lawrence).

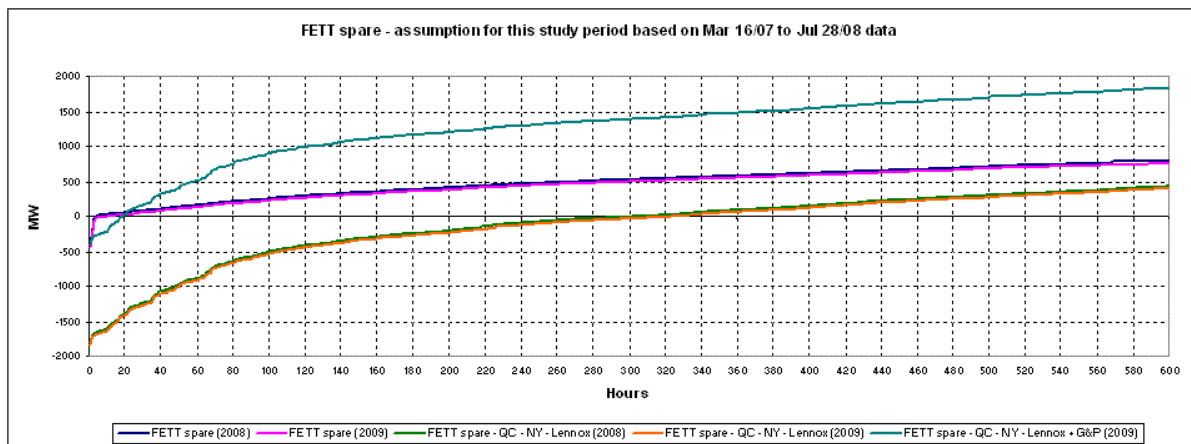
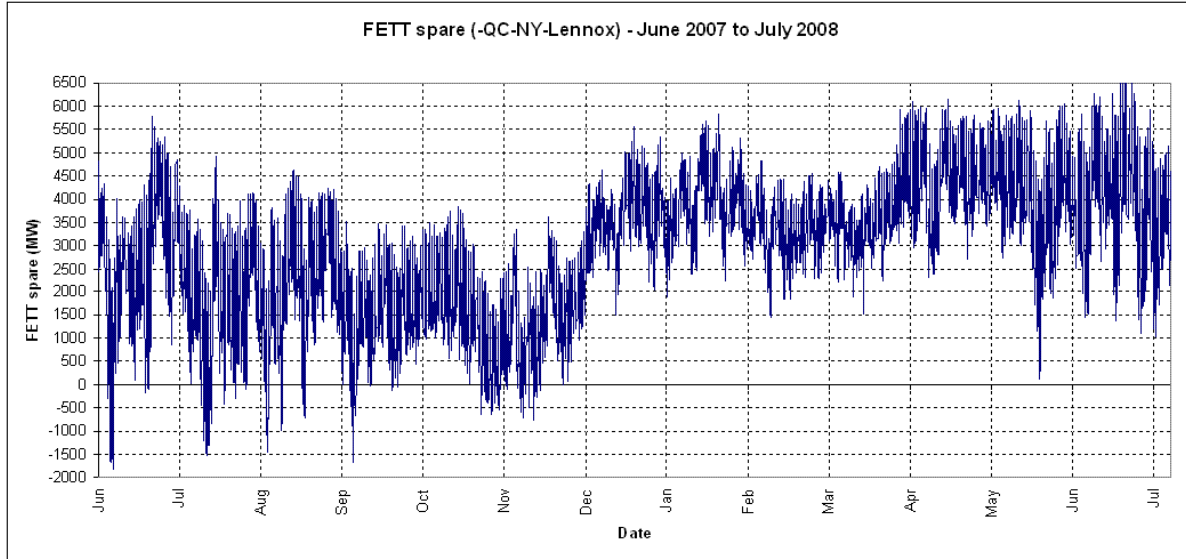

**Figure 12: FETT 2009 forecast**

With Portlands Energy Center and Goreway Station in service FETT control could be necessary for about 20 hours. A projection for 2010 is expected to be fairly similar to 2009 except the number of

hours requiring Lennox support may slightly increase due to the expected demand growth but can also decrease if the summer is milder compared to 2007.

Figure 3 section 5.2 shows that Lennox support was required to respect the FETT limit 228 hours. Most of these hours were during the summer and some during fall/winter:



**Figure 13: FETT spare from June 2007 to July 2008**

The period from June 2007 to July 2008 was selected for this graph to allow for consistent revision of numbers over the similar period of 2009 when all new facilities mentioned in this report are supposed to be in service. Considering that Portlands Energy Center and Goreway Station are both available the projected FETT spare for summer 2009 would change correspondingly (values capped at 6000 MW):

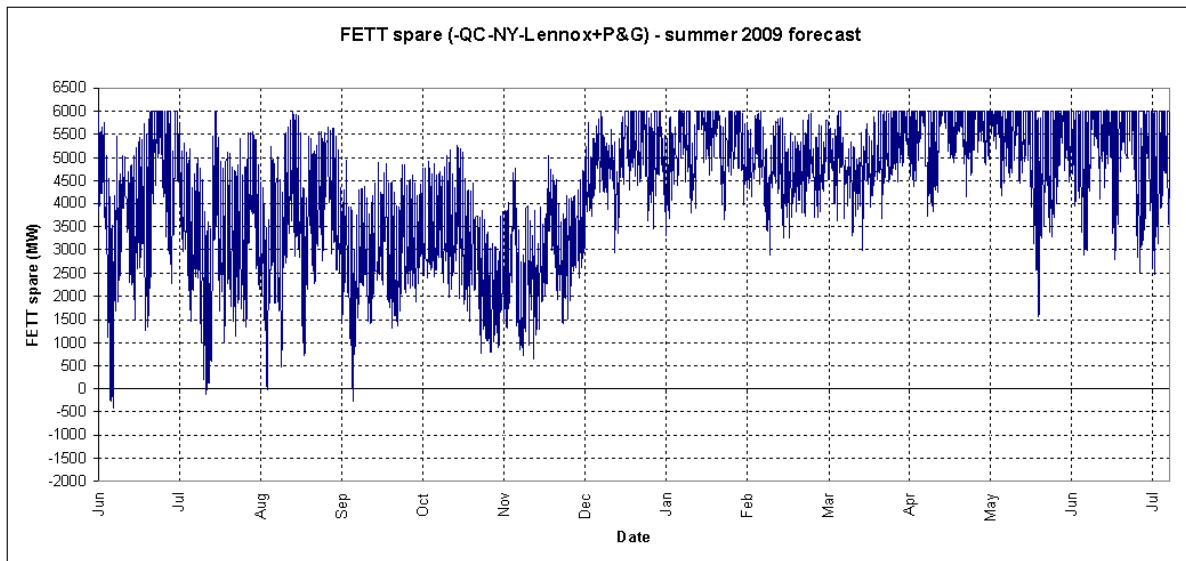

**Figure 14: FETT spare summer 2009 & 2010 based on 2007 & available 2008 data**

Figure 14 shows that for FETT control may still be marginally required during summer 2009. If summer 2010 is as mild as 2008 FETT control may no longer be required post September 2009. FETT control within the same limited number of hours may be required if summer 2010 is more similar with summer 2007:

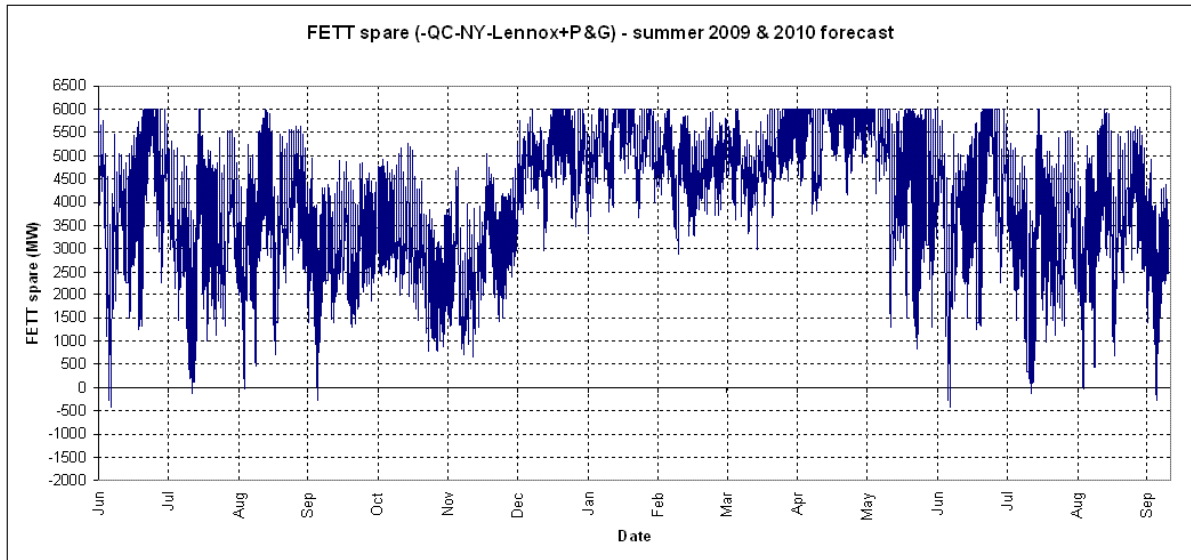

**Figure 15: FETT spare summer 2009 & 2010 based on 2007 data**

Additional to the resources already mentioned, in spring 2010 Halton Hills GS is scheduled to go in service. The presence of this plant will bridge the output gap between Portlands Energy Center plus Goreway Station and Lennox. As a result Lennox may no longer be required for FETT control during summer 2010. Unexpected changes in the local resources availability or demand forecast may trigger the need for additional studies to re-assess the requirement for Lennox past the end of the current term.

## 6.2 Reliable supply to Ottawa

Under the current limit structure the Lennox units can be used to improve the FIO limit by up to 300 MW. The first two units help improve the limit by 75 MW each, adding to 150 MW when both units are in service. Further improvements can be obtained by arming load rejection in Ottawa with support from the other two Lennox units. For each unit, up to 75 MW of load rejection can be armed which would improve the limit by another 150 MW. This improvement may be needed to reliably supply Ottawa demand when transmission elements are taken out of service for maintenance. This limit structure is expected to change in anticipation of commissioning the new HVDC connection with Hydro Quebec and its associated facilities.

The following table compares pre-contingency and post-contingency voltages at several buses at Ottawa (including Lennox) for several different assumptions. For the purpose of this study the most limiting single-element contingency is normally the loss one of the Lennox to Hawthorne 500 kV circuits X522A, or X523A.

Scenarios:

1. Lennox in service and at full capacity;
2. Lennox out of service, Goreway and Portlands in service;
3. 150 MW load rejection armed in Ottawa for scenarios 1 and 2;
4. 300 MW load rejection armed in Ottawa for scenarios 1 and 2.

All scenarios assume the new Hawthorne capacitors in service with no flow on the DC line in or out of Ontario for consistency.

**Table 4: Post X522A contingency voltage deviation comparison**

Scenario:		1	2	3	4	1->2		3->4	
Bus name:		kV	kV	kV	kV	kV	%	kV	%
HAWTHORN	500.00	546	527	546	523	18	3%	24	4%
HAWTHORN	220.00	248	245	248	245	3	1%	3	1%
HAWTHORN	118.05	126	125	126	125	2	1%	2	1%
MERIVALE	220.00	246	243	246	243	3	1%	3	1%
MER A1D1	118.05	123	122	123	122	1	1%	1	1%
MER A2T2	118.05	127	125	127	125	2	1%	2	1%
LENNOX	500.00	545	540	545	533	6	1%	12	2%
LENNOX	220.00	249	247	248	245	1	1%	2	1%

Scenarios:

1. – All elements in service, Lennox in service, Goreway and Portlands out of service
2. – Post X522A contingency (post-tap change), Lennox in service, Goreway and Portlands out of service
3. – All element in service, Lennox out of service, Goreway and Portlands in service
4. – Post X522A contingency (post-tap change), Lennox out of service, Goreway and Portlands in service.

The post contingency values in table 5 were taken after transformer automatic under-load tap changer action. The calculated post-contingency voltage deviation in both cases is within acceptable limits.

The IESO planning criteria requires that the maximum acceptable pre-contingency power transfer must be the lesser of:

- A pre-contingency power transfer that is 10% lower than the voltage instability point of the pre-contingency curve and
- A pre-contingency transfer that results in a post-contingency power flow that is 5% lower than the voltage instability point of the post-contingency curve.

Table 4 base cases were used to generate the following P-V curves:

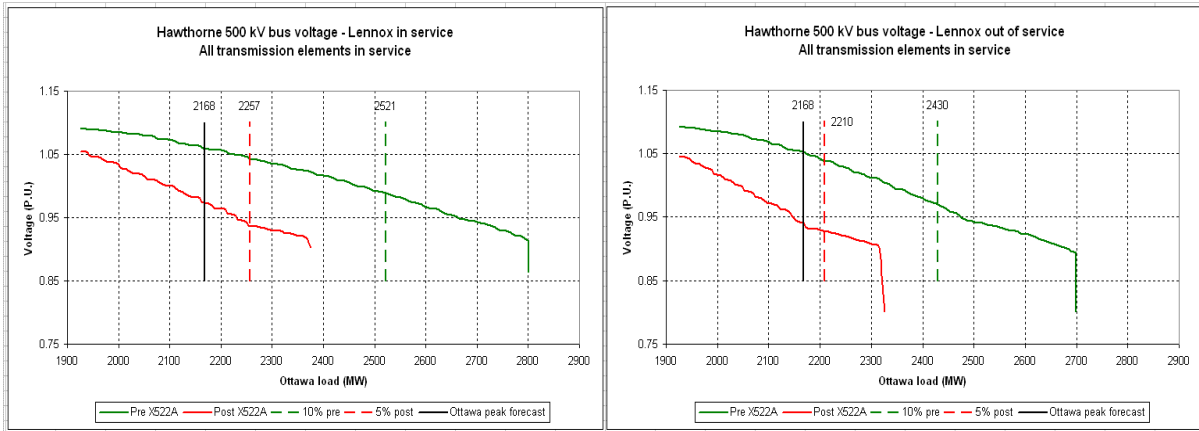

**Figure 16: Hawthorne 500 kV P-V curves - all elements in service**

Both scenarios show sufficient margin to allow reliable supply of the expected demand forecast, although the post contingency reserve with Lennox in service (99 MW) is about twice as high as without Lennox (51 MW). The Ottawa peak shown in this analysis is the highest forecast published in the latest 18-month outlook.

This post contingency reserve is rapidly consumed if one element is out of service for maintenance. The following example shows the impact of L24A from St. Lawrence to Hawthorne:

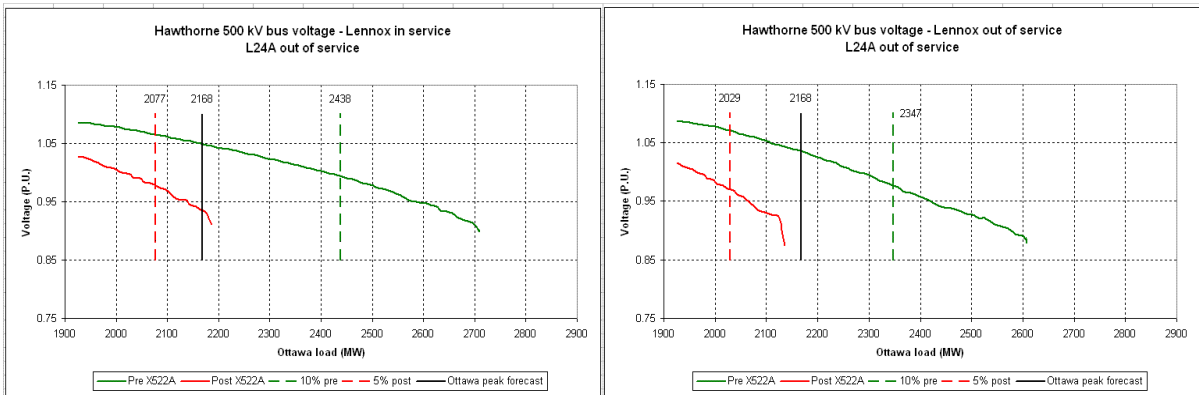

**Figure 17: Hawthorne 500 kV P-V curve - L24A out of service**

Figure 17 shows that the 5% post contingency criterion is no longer satisfied in both cases. With Lennox in service this criterion is exceeded by 91 MW and with Lennox out of service by 139 MW. The simulation shows that the criterion is exceeded by a lesser amount with Lennox in service than without Lennox.

The Ontario Resource and Transmission Assessment Criteria, section 7.1 – Load Security Criteria allows for up to 150 MW of load rejection to be armed if two elements are (expected to be) out of service. Load rejection exceeding 150 MW is permissible only to account for local generation outages. There is very little generation in Ottawa and for these simulations it was all considered in service. The total amount of load rejection that can be armed in Ottawa adds to about 815 MW:

**Table 5: Load rejection availability in Ottawa zone**

Station name	Peak load (MW)
Nepean	120
Albion	125
South March	95
Lincoln Heights	60
Hawthorne	110
Overbrooke	95
Russell	50
Longueuil	85
St. Isidore	75
Total	815

The current operational documents only permit load rejection in Ottawa to be armed when Lennox units are synchronized to the grid and the maximum amount of load rejection that can be armed is 300 MW when all four Lennox units are in service. As a result, under the current limit structure, the load rejection improvement with Lennox out of service shown by the following figures can only be taken advantage of in real time operations if the limit structure is revised. For consistency, the simulations were performed with 150 MW and 300 MW load rejection.

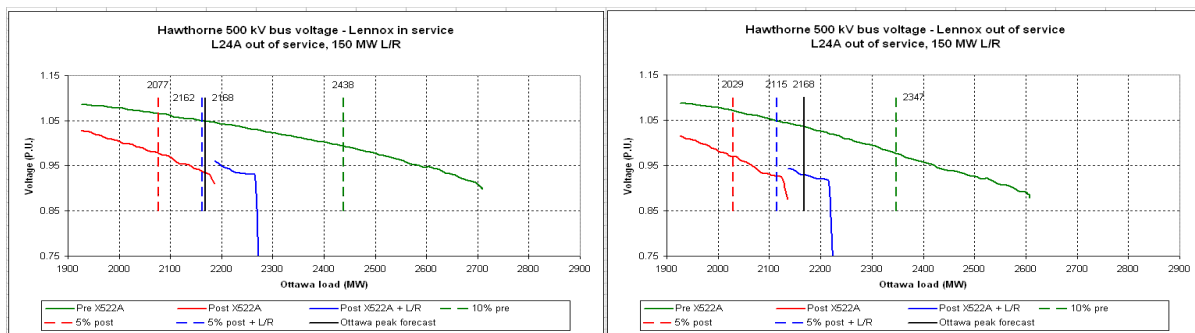

**Figure 18: Hawthorne 500 kV P-V curve - L24A out of service, 150 MW L/R**

The criterion is not satisfied even if 150 MW of load rejection is armed in Ottawa. Figure 18 shows that with Lennox in service the highest load in Ottawa is just 6 MW above the limit while with Lennox out of service the limit is exceeded by 53 MW.

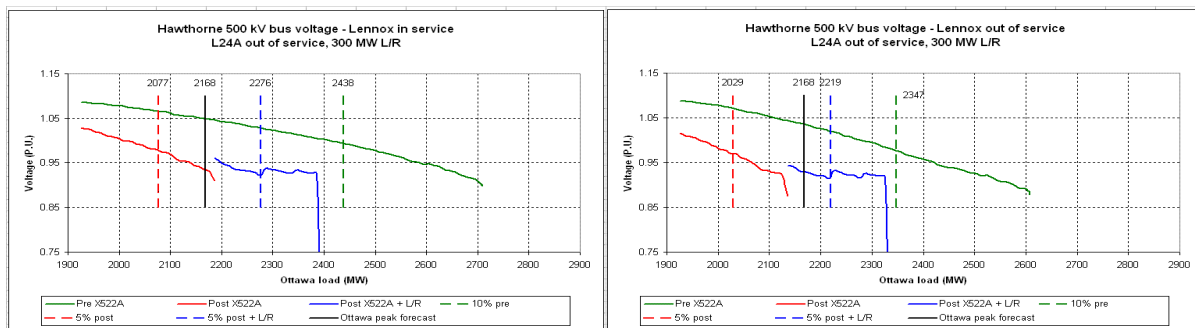

**Figure 19: Hawthorne 500 kV P-V curve - L24A out of service, 300 MW L/R**

If 300 MW of load rejection is armed the 5% post-contingency criterion is satisfied in both cases. A detailed review of the operating limits for the Ottawa area is currently underway, and it is anticipated that a limit improvement using load rejection can be achieved when Lennox units are out of service.

A preliminary forecast for Ottawa from July 01, 2008 to December 31, 2010 was used to assess the amount of time this local area supply may be exceeding the 5% post-contingency

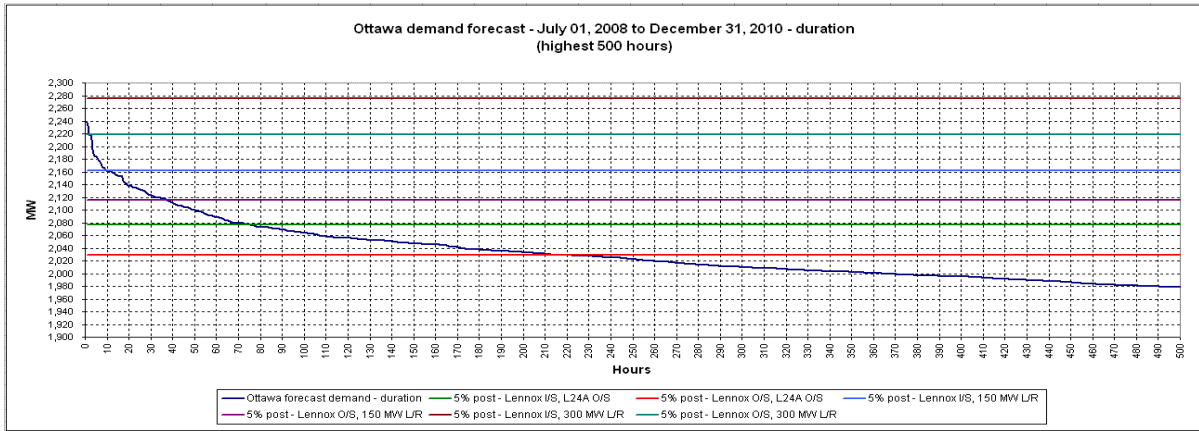

Figure 20: Ottawa demand forecast from Jul 01/08 to Dec 31/10 - duration

Table 6: Hours exceeding the 5% post-contingency criterion

Scenario (L24A O/S)	Hours
Lennox O/S, no L/R	217
Lennox I/S, no L/R	73
Lennox O/S, 150 MW L/R	37
Lennox I/S, 150 MW L/R	9
Lennox O/S, 300 MW L/R	1
Lennox I/S, 300 MW L/R	0

Table 6 shows the number of hours the 5% post-contingency criterion is exceeded for the four scenarios studied. The hourly data was used to determine the most likely time period these hours may occur:

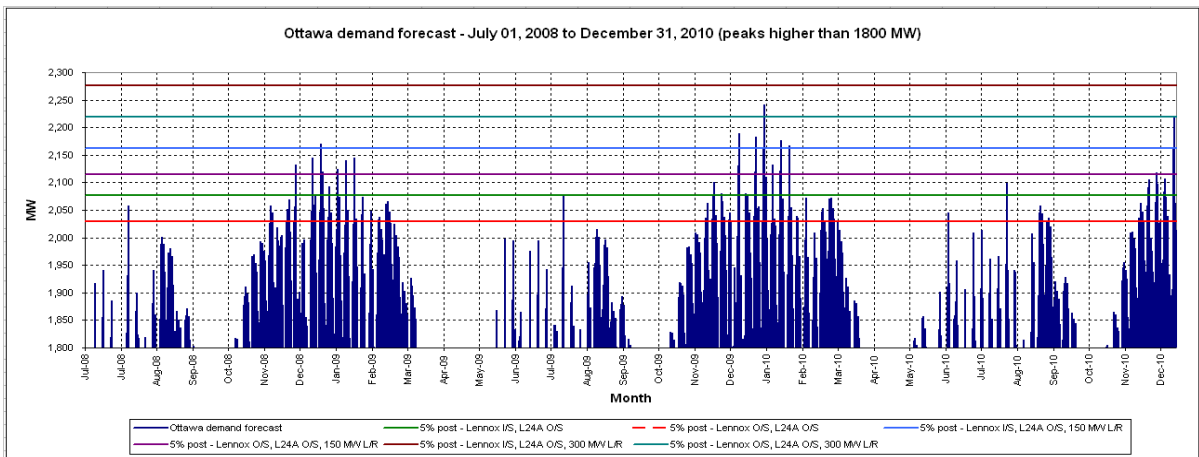
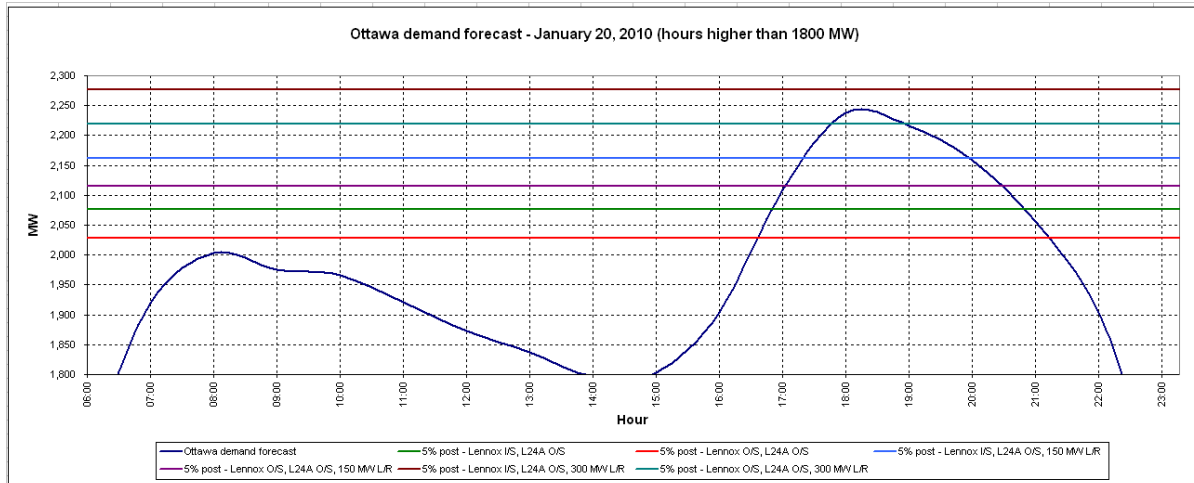

Figure 21: Ottawa demand forecast from Jul 01/08 to Dec 31/10 - duration

Figure 21 shows that most of the hours on Table 6 (and Figure 20) are expected to occur during the cold season. January 20, 2010 data was chosen to better understand how these results would impact the Ottawa supply:



**Figure 22: Ottawa - January 22, 2010**

Depending on the scenario, load reduction measures that would last from about one hour to almost five hours on the highest loaded day between hours 16:00 and hour 22:00 may be required if insufficient margin is available to reliably supply the zone.

Section 5.4 indicated that over the last few years Ottawa peaked in the summer mainly due to milder weather during the cold season. This trend may continue over the next few years, in which case the number of hours this criterion is exceeded will be much lower, but if (one of) the following two cold seasons (is) are not as mild as the previous two Lennox support may still be required to ensure adequate supply for Ottawa.

The operating documents currently in force only allow load rejection in Ottawa to be armed if Lennox units are synchronized to the grid. Incorporation of the supporting facilities for the DC connection to Quebec is expected to result in a limit structure change that will allow arming of load rejection in Ottawa when all Lennox units are disconnected from the grid. As a result, Lennox support may no longer be required beyond September 2009 for reliably supply the Ottawa zone if sufficient load rejection can be armed.

Dynamic simulations were performed to identify how Lennox retirement would impact the post-contingency transient stability of the Ottawa zone. It was determined that no significant impact would result from de-registering Lennox over the post contingency dynamic stability of the system (results in Appendix C).

**– End of Section –**

## Appendix A: Demand forecast

**Table 7: Zonal demand forecast from January 2008 to December 2009 – extreme weather, firm resource scenario per the latest 18-month outlook.**

Date	Bruce	East	Essa	Niagara	NorthEast	NorthWest	Ottawa	SouthWest	Toronto	West	Ontario
Jan-08	97	1,866	1,614	810	1,769	814	2,102	4,890	8,255	2,490	24,707
Feb-08	94	1,835	1,600	784	1,710	771	2,072	4,838	8,186	2,421	24,309
Mar-08	87	1,675	1,472	745	1,624	778	1,904	4,624	7,886	2,362	23,158
Apr-08	58	1,353	1,203	737	1,499	636	1,597	4,202	7,949	2,408	21,643
May-08	58	1,453	1,344	841	1,344	677	1,701	4,669	9,070	2,750	23,906
Jun-08	66	1,600	1,506	1,017	1,359	723	1,976	5,237	10,266	3,264	27,015
<b>Jul-08</b>	<b>62</b>	<b>1,617</b>	<b>1,550</b>	<b>1,061</b>	<b>1,327</b>	<b>689</b>	<b>1,958</b>	<b>5,368</b>	<b>10,746</b>	<b>3,364</b>	<b>27,741</b>
Aug-08	65	1,613	1,564	1,061	1,381	686	1,981	5,295	10,574	3,372	27,593
Sep-08	66	1,522	1,402	978	1,423	642	1,938	5,107	9,822	3,116	26,016
Oct-08	92	1,725	1,489	753	1,691	784	1,968	4,728	8,070	2,358	23,656
Nov-08	93	1,748	1,523	777	1,678	768	1,992	4,829	7,999	2,447	23,852
Dec-08	94	1,798	1,555	808	1,777	795	2,048	4,927	8,249	2,547	24,598
Jan-09	102	1,926	1,685	808	1,811	800	<b>2,168</b>	5,023	8,444	2,538	25,306
Feb-09	99	1,895	1,676	782	1,761	766	2,139	4,975	8,362	2,469	24,924
Mar-09	93	1,727	1,548	748	1,710	769	1,974	4,756	8,065	2,417	23,806
Apr-09	62	1,388	1,301	767	1,364	681	1,663	4,401	8,241	2,495	22,362
May-09	61	1,456	1,382	835	1,345	663	1,714	4,731	9,134	2,765	24,086
Jun-09	68	1,600	1,534	1,007	1,353	710	1,975	5,310	10,340	3,273	27,169
<b>Jul-09</b>	<b>65</b>	<b>1,618</b>	<b>1,577</b>	<b>1,056</b>	<b>1,331</b>	<b>675</b>	<b>1,969</b>	<b>5,434</b>	<b>10,829</b>	<b>3,375</b>	<b>27,930</b>
Aug-09	66	1,615	1,598	1,056	1,379	672	1,992	5,356	10,645	3,385	27,764
Sep-09	67	1,523	1,435	971	1,449	671	1,940	5,159	9,866	3,123	26,205
Oct-09	62	1,340	1,204	838	1,388	648	1,714	4,677	9,135	2,733	23,740
Nov-09	95	1,733	1,538	766	1,677	747	2,011	4,879	8,007	2,451	23,904
Dec-09	99	1,793	1,591	795	1,758	749	2,093	4,980	8,277	2,535	24,670

– End of Section –



## Appendix B: PSS/E model used for simulations.

A summary of the two base cases used in simulation are shown below:

**Table 8 : Summer 2009 extreme weather demand, Lennox I/S, Goreway and Portlands O/S**

Zone	Zone ID	Total Generation (MW)	Hydroelectric Generation (MW)	Load (MW)	Ties (MW)	Demand
NORTHWST	1	853	552	620	180	672
NORTHEST	2	2239	1859	1215	910	1329
ESSA	3	344	325	1530	-1228	1573
OTTAWA	4	61	0	1926	-1904	1965
EAST	5	3798	1446	1561	2180	1618
TORONTO	6	7094	0	10675	-3738	10832
NIAGARA	7	1670	1670	1030	613	1057
SOUTHWST	8	3524	0	5245	-1954	5477
BRUCE	9	4908	0	50	4839	68
WEST	10	4292	0	3260	887	3405
STATNLD	11	0	0	954	-947	947
IESO	1	28946	5853	28066	0	27991

**Table 9: Summer 2009 extreme weather demand, Lennox O/S, Goreway and Portlands I/S**

Zone	Zone ID	Generation (MW)	Hydroelectric Generation (MW)	Load (MW)	Ties (MW)	Demand
NORTHWST	1	853	552	620	180	673
NORTHEST	2	2239	1859	1215	910	1329
ESSA	3	344	325	1530	-1228	1572
OTTAWA	4	61	0	1926	-1901	1962
EAST	5	1719	1446	1561	112	1606
TORONTO	6	8554	0	10675	-2272	10826
NIAGARA	7	1745	1745	1030	686	1060
SOUTHWST	8	3524	0	5245	-1972	5496
BRUCE	9	4908	0	50	4839	69
WEST	10	4868	0	3260	1431	3437
STATNLD	11	0	0	954	-947	947
IESO	1	28978	5928	28066	0	28024

– End of Section –

# Appendix C: Dynamic simulation results

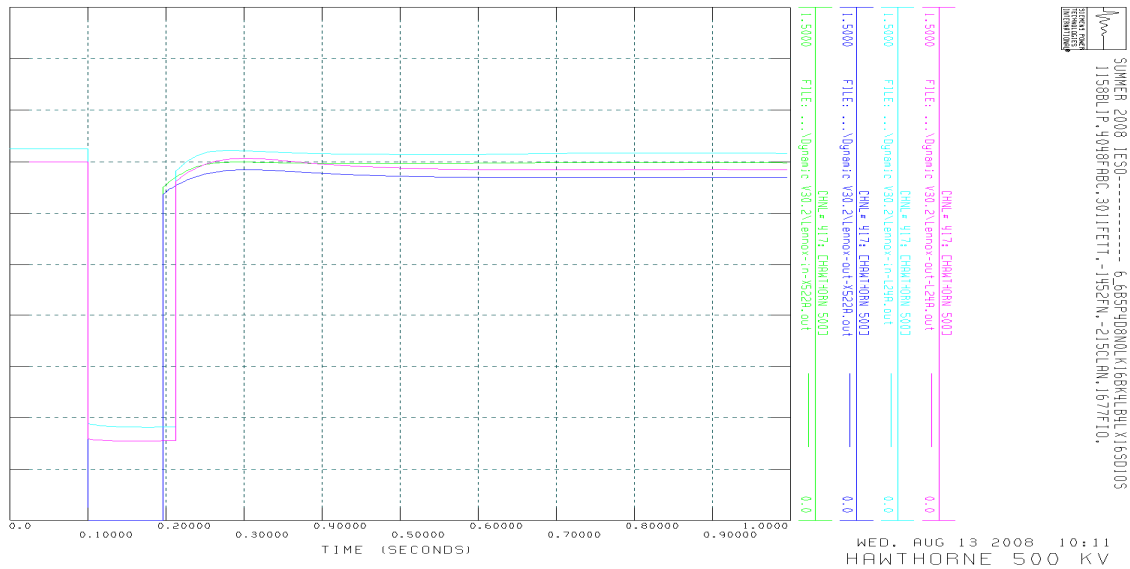

**Figure 23: Hawthorne 500 kV bus voltage post X522A and L24A contingencies with and without Lennox**

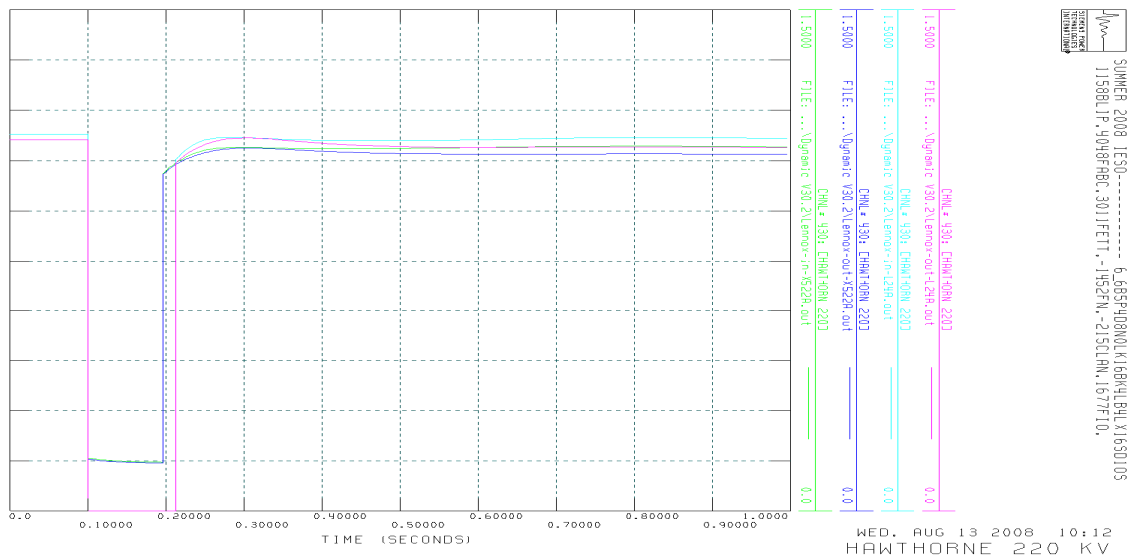

**Figure 24: Hawthorne 220 kV bus voltage post X522A and L24A contingencies with and without Lennox**

– End of Section –

# References

---

Document Name	Document ID
Lennox GS Deregistration Analysis Oct 2006 – Sep 2007 issue 2.0	
Lennox GS Deregistration Analysis Oct 2007 – Sep 2008 issue 2.0	IESO_REP_0393

– End of Document –