

# PROCEDURE



Power to Ontario.  
On Demand.

---

## Market Manual 3: Metering

# Part 3.7: Totalization Table Registration

---

Issue 16.0

This procedure describes the process through which *metering service providers* submit Totalization Tables and approve the tables entered by the *IESO* in the *metering registry*.

## Disclaimer

The posting of documents on this Web site is done for the convenience of *market participants* and other interested visitors to the *IESO* Web site. Please be advised that, while the *IESO* attempts to have all posted documents conform to the original, changes can result from the original, including changes resulting from the programs used to format the documents for posting on the Web site as well as from the programs used by the viewer to download and read the documents. The *IESO* makes no representation or warranty, express or implied, that the documents on this Web site are exact reproductions of the original documents listed. In addition, the documents and information posted on this Web site are subject to change. The *IESO* may revise, withdraw or make final these materials at any time at its sole discretion without further notice. It is solely your responsibility to ensure that you are using up-to-date documents and information.

This *market manual* may contain a summary of a particular *market rule*. Where provided, the summary has been used because of the length of the *market rule* itself. The reader should be aware, however, that where a *market rule* is applicable, the obligation that needs to be met is as stated in the *market rules*. To the extent of any discrepancy or inconsistency between the provisions of a particular *market rule* and the summary, the provision of the *market rule* shall govern.

<b>Document ID</b>	IMP_PRO_0047
<b>Document Name</b>	Part 3.7: Totalization Table Registration
<b>Issue</b>	Issue 16.0
<b>Reason for Issue</b>	Release for Baseline 24.0
<b>Effective Date</b>	September 8, 2010

## Document Change History

Issue	Reason for Issue	Date
1.0	Unapproved version for Baseline 5.0	January 4, 2001
2.0	Board Approved version released for Baseline 6.0	February 16, 2001
3.0	Released for Baseline 6.2	May 19, 2001
4.0	Baseline 6.3	July 16, 2001
5.0	Baseline 7.0	January 14, 2002
6.0	Update to Baseline 7.0	March 25, 2002
7.0	Revision to incorporate legal review	April 23, 2002
8.0	Released for Baseline 9.0	March 5, 2003
9.0	Released for Baseline 13.1	June 1, 2005
10.0	Released for Baseline 14.0	September 14, 2005
11.0	Released for Baseline 16.0	September 13, 2006
12.0	Released for Baseline 17.0	March 7, 2007
13.0	Released for Baseline 17.1	June 6, 2007
14.0	Released for Baseline 18.0	September 12, 2007
15.0	Released for Baseline 19.0	March 5, 2008
16.0	Released for Baseline 24.0	September 8, 2010

## Related Documents

Document ID	Document Title
MDP_PRO_0013	Market Manual 3: Metering, Part 3.2: Meter Point Registration and Maintenance
MDP_MAN_0003	Market Manual 3: Metering, Part 3.0: Metering Overview
MDP_PRO_0010	Market Manual 3: Metering, Part 3.4: Measurement Error Correction
MDP_PRO_0011	Market Manual 3: Metering, Part 3.5: Site Specific Loss Adjustments
MDP_PRO_0012	Market Manual 3: Metering, Part 3.6: Conceptual Drawing Review
IMP_PRO_0057	Market Manual 3: Metering, Part 3.8 Creating and Maintaining Delivery Point Relationships
MDP_STD_0004	Wholesale Revenue Metering Standard - Hardware
MDP_STD_0005	Site-Specific Loss Adjustments Standard



# Table of Contents

---

<b>Table of Contents</b> .....	<b>i</b>
<b>List of Figures</b> .....	<b>iii</b>
<b>List of Tables</b> .....	<b>iii</b>
<b>Table of Changes</b> .....	<b>iv</b>
<b>Market Manuals</b> .....	<b>1</b>
<b>Market Procedures</b> .....	<b>1</b>
<b>Introduction</b> .....	<b>2</b>
<b>1. 2</b>	
1.1 Purpose.....	2
1.2 Scope .....	2
1.3 Overview .....	2
1.4 Who Should Use This Document.....	2
1.5 Roles and Responsibilities.....	2
1.6 Contact Information .....	3
<b>2. Procedure Overview</b> .....	<b>4</b>
2.1 General Outline .....	4
2.2 Important Terms .....	5
2.2.1 Delivery Point.....	5
2.2.2 Meter Point ID.....	5
2.2.3 Summary Meter .....	5
2.2.4 Measurement Error Correction (MEC) Factors .....	5
2.2.5 Site-Specific Loss Adjustment (SSLA).....	5
2.2.6 Total Loss Factors (TLF).....	6
2.2.7 Totalization Table Notes .....	6
2.3 Guidelines for Preparing Totalization Tables .....	6
2.3.1 Estimated Station Services .....	6
2.3.2 Estimated Station Services Using Retail Meters.....	7
2.3.3 Apportioning Station Service Consumption .....	7
2.3.4 Apportioning Transformation Losses .....	8
2.3.5 Transmission Tariffs (TT) Customers .....	9
2.3.6 Compliance Aggregation.....	9

2.3.7	Meter Disaggregation.....	11
2.4	Applications Associated with the Creation of Totalization Table .....	13
2.4.1	Participant Life Cycle (PLC) .....	13
2.4.2	MV-90.....	13
2.4.3	MV-STAR .....	13
2.4.4	MV-WEB.....	13
2.4.5	Commercial Reconciliation.....	13
2.5	Supporting Documentation .....	14
2.5.1	Submitting the Information .....	14
2.5.2	Confirming Correctness of the Totalization Tables .....	14
2.6	Maintaining Totalization Tables .....	14
2.7	Site Registration Report .....	15
<b>3.</b>	<b>Procedural Work Flow .....</b>	<b>17</b>
<b>4.</b>	<b>Procedural Steps .....</b>	<b>20</b>
	<b>Appendix A: Forms .....</b>	<b>A-1</b>
	<b>Appendix B: Guidelines for Completing the Totalization Table Form .....</b>	<b>B-1</b>
	<b>Appendix C: Example of Totalization .....</b>	<b>C-1</b>
	<b>Appendix D: Metering - Settlement Principles.....</b>	<b>D-1</b>
	<b>Appendix E: Example of a Site Registration Report (SRR) .....</b>	<b>E-1</b>
	<b>Appendix F: Example of a Compliance Aggregation Model.....</b>	<b>F-1</b>
	<b>Appendix G: Example of a Meter Disaggregation Model .....</b>	<b>G-1</b>
	<b>References.....</b>	<b>1</b>

## List of Figures

---

Figure 3–1: Work flow for Totalization Table Registration..... 18  
Figure 3–1: Work Flow for Totalization Table Registration (continued)..... 19  
Figure C–1: Single Line Diagram for Pine TS T5/T6..... C–1

## List of Tables

---

Table 3–1: Legend for Procedural Work Flow Diagrams ..... 17  
Table 4–1: Procedural Steps for Totalization Table Registration ..... 21  
Table C–1: Totalization Table Form ..... C–2  
Table C–1: Totalization Table Form (continued)..... C–3  
Table C–1: Totalization Table Form (continued)..... C–4

## Table of Changes

---

<b>Reference (Section and Paragraph)</b>	<b>Description of Change</b>
Section 2.3.1	<ul style="list-style-type: none"><li>- Section name changed from “Metered Station Services” to “Estimated Station Services”</li><li>- Revised assumptions used in determining the <i>station service</i> factor</li></ul>
Section 2.3.2	<ul style="list-style-type: none"><li>- Section named changes from “Meter Station Services” to “Estimated Station Services Using Retail Meters”.</li><li>- Updated items to consider when using retail meters.</li></ul>

# Market Manuals

---

The *market manuals* consolidate market procedures and associated forms, standards and policies that define certain elements relating to the operation of the *IESO-administered markets*. Market procedures provide more detailed descriptions of the requirements for various activities than is specified in the *market rules*. Where there is a discrepancy between the requirements in a document within a *market manual* and the *market rules*, the *market rules* must prevail. Standards and policies appended to, or referenced in, these procedures provide a supporting framework.

## Market Procedures

---

The “Metering Manual” is Volume 3 of the *market manuals*, and this document is “Part 3.7: Totalization Table Registration”.

A list of the other component parts of the *metering manual* is provided in “Part 3.0: Metering Overview”, in Section 2, “About This Manual”.

## Structure of Market Procedures

Each market procedure is composed of the following sections:

1. **“Introduction”**, which contains general information about the procedure, including an overview, a description of the purpose and scope of the procedure, and information about roles and responsibilities of the parties involved in the procedure.
2. **“Procedural Work Flow”**, which contains a graphical representation of the steps and flow of information within the procedure.
3. **“Procedural Steps”**, which contains a table that describes each step and provides other detail related to each step.
4. **“Appendices”**, which may include such items as forms, standards, policies and agreements.

## Conventions

The *market manual* standard conventions are as defined in the “Market Manual Overview” document.

- End of Section –

# 1. Introduction

---

## 1.1 Purpose

This procedure explains how to register totalization tables with the *IESO*.

## 1.2 Scope

This procedure covers the steps for totalization table registration, which is part of the registration process for *metering installations*. Other procedures in “Market Manual 3: Metering” may need to be performed before, after or in parallel to the steps in this procedure, depending on the activity that is being performed:

1. “Part 3.8: Creating and Maintaining Delivery Point Relationships” describes how the *IESO* creates *delivery points* for both *energy market* and *transmission tariffs* customers. *Delivery points* must be set up by the *IESO* before *meter point* registration can begin. Additional details regarding the creation of *delivery points* for the *energy market* are given in *IESO*’s “Market Manual 1: Market Entry, Maintenance and Exit, Part 1.2: Facility Registration, Maintenance and De-registration”
2. “Part 3.2: Meter Point Registration and Maintenance”. *Meter point* registration during which the *metering installation* is assessed technically and, once approved by the *IESO*, entered into the *IESO metering registry*.

## 1.3 Overview

A complete overview of the steps in this document appears in Section 2.

## 1.4 Who Should Use This Document

*Transmitters, metering service providers, and metered market participants* should use this procedure to register a totalization table with the *IESO*.

## 1.5 Roles and Responsibilities

The roles and responsibilities, with regard to the tasks associated with the current procedure, of the *metered market participant, metering service provider, transmitter, and the IESO*, are as follows:

The *metered market participant* is responsible for:

- for a *transmission tariffs delivery point* (MMPT) feeding an *embedded generator(s)* built after 1998 that does not participate in the *energy market*, ensuring that the relevant *meter(s)* to be used for *transmission tariffs* only, are registered with the *IESO*.

The *metering service provider* is responsible for:

- submitting totalization tables associated with each *delivery point* associated with a specific *metered market participant*;
- when submitting a new totalization table, identifying all other totalization tables that are affected and communicating with the relevant *metering service providers* to ensure these totalization tables are also re-submitted;
- re-submitting totalization tables, as appropriate; and
- signing the “Site Registration Report” produced by the *IESO*, thus confirming that the totalization table has been correctly entered into the *IESO meter* registry.

The *transmitter* is responsible for.

- verifying the totalization tables submitted by the *metering service provider* for reasonableness and completeness;
- signing the “Site Registration Report” produced by the *IESO*, thus confirming that the totalization table has been correctly entered into the *IESO meter* registry.

The *IESO* is responsible for:

- processing and entering the totalization table into MV-STAR (the *metering registry*); and
- generating the “Site Registration Report” for the relevant *delivery point* on which the *metering service provider* will acknowledge correctness.

## 1.6 Contact Information

If the *market participant* wishes to contact the *IESO*, the *market participant* can contact the *IESO* Customer Relations via email at [customer.relations@ieso.ca](mailto:customer.relations@ieso.ca) or via telephone, mail or courier to the numbers and addresses provided on the *IESO* Web site ([www.ieso.ca](http://www.ieso.ca)) – or click on “Have a Question?” to go to the “Contacting the *IESO*” page). If the *IESO* Customer Relations is closed, telephone messages or emails can be left in relevant voice or electronic *IESO* mail boxes, which will be answered as soon as possible by Customer Relations staff.

Standard forms that participants must complete for this procedure are listed in Appendix A. These forms are generally available for downloading on the *IESO* Web site. These signed forms as well as the accompanying supporting documentation must be transmitted to the *IESO* via mail or courier by using the appropriate address provided on the *IESO* Web site or on the form. All correspondence relating to this procedure shall identify the subject: **Totalization Table Registration**.

– End of Section –

## 2. Procedure Overview

---

### 2.1 General Outline

The totalization table algebraically maps *meter point* IDs to a *delivery point*. The totalization table also identifies any measurement error correction factors, site specific losses, *station service* load and, if applicable, total loss factors to be applied to *meter* readings at each *meter point*. The *IESO* uses this data, adjusted and summated at the *delivery point*, to:

- settle *metered market participant* transactions in the wholesale *energy market*; and/or
- calculate transmission charges for *transmission tariffs* customers (see also Section 2.3.4 in this manual).

At this time, *metering service providers* are required to supply the information set-out in Appendix B. The *IESO* will further process this information to create the required summary *meters* and enter them into the *meter* registry.

This approach will change for the enduring stage when, on registering a new *meter point ID*, the *metering service provider* must submit a complete totalization table for that *delivery point*. On submitting a new totalization table, an embedded metering service provider must also identify all other totalization tables that are affected and prompt the relevant *metered market participant(s)* to re-submit them. In this document, the term “embedded metering service provider/metered market participant” means those connected to a bus, the *meter* of which is serviced/owned by another *metering service provider/metered market participant*.

The *IESO* uses two types of totalization tables:

1. totalization tables for *energy market delivery points* (EM DP); and
2. totalization tables for *transmission tariffs delivery points* (TT DP) (see Section 2.3.4 in this manual), which are further divided into the following types:
  - totalization tables for Network DPs; and
  - totalization tables for Connection DPs.

Multi-level totalization tables, such as the ones for *facilities* equipped with both bus and feeder metering, and where one or more feeders also supply embedded loads, must be built in the following order:

1. embedded;
2. feeders; and
3. bus.

## 2.2 Important Terms

### 2.2.1 Delivery Point

The *delivery point* is the logical reference point for *settlements* in the wholesale *energy market*, and for the *transmission tariffs* market. Totalization tables submitted during MI registration are always associated with a *delivery point*. Separate *delivery points* are created for *transmission tariffs* customers, as described in “Part 3.8: Creating and Maintaining Delivery Point Relationships”.

### 2.2.2 Meter Point ID

The *meter point* ID identifies the physical location of the *metering installation* with a unique numerical code. During the registration procedures, the *IESO* enters the *meter point* ID(s) on the Single Line Diagram, before returning it to the *metering service provider*.

Separate *meter point* IDs are created for the main and the alternate (or *check*) *meter* pertaining to the same installation. However, only main or stand-alone *meters* are considered for totalization.

### 2.2.3 Summary Meter

A summary *meter* is a virtual *meter* created as part of the totalization process. The summary *meter* is a mathematical tool that can summate readings from various *meters* and apply losses, error correction factors, and/or scaling factors to these readings in order to enable the *settlement* at the associated *delivery point*. There are three main scenarios in which summary *meters* are required to be created, as listed below:

1. Recorders that include two or more metering channels that measure active *energy* flow (kWh) in the same direction. Such situations require the creation of separate summary (virtual) *meters* for each metering element involved.
2. Totalization table. In most of the cases, the totalization table is a summary *meter* that considers various physical and/or summary *meters* with MECs, loss factors, and scaling, all applied at different levels (physical *meter* and/or summary *meter*).
3. Summary *meters* associated with an *energy market* DP that are used as contributors for totalization tables associated with a TT DP.

### 2.2.4 Measurement Error Correction (MEC) Factors

MEC factors are calculated in accordance with the process set out in “Part 3.4: Measurement Error Correction”. Although these factors generally apply to a physical *meter*, they can also apply to a summary *meter*. MEC factors must be entered in the totalization table as the calculated MEC factor minus one. Thus, for a calculated MEC factor of 1.005, a value of 0.005 must be entered in the totalization table; a calculated MEC factor of 0.995 must be entered as “-0.005”.

### 2.2.5 Site-Specific Loss Adjustment (SSLA)

SSLA factors are calculated in accordance with the process set out in “Part 3.5: Site Specific Loss Adjustment”. SSLA factors take into account transformation losses. Similar to MEC factors, SSLA factors can be applied to a physical *meter* or to a summary *meter*, as appropriate.

## 2.2.6 Total Loss Factors (TLF)

TLFs take into account distribution losses for *embedded RWMs* to the *defined meter point*. TLF, as approved by the *Ontario Energy Board (OEB)* and communicated by the relevant LDC, can be applied to a *physical meter* or to a *summary meter*, as appropriate. The values for Total Loss Factors must be entered in the same manner as described for MEC factors, above. Refer to Appendix D for details.

## 2.2.7 Totalization Table Notes

*Metering service providers* may utilize the notes section of the Totalization Table to clarify instructions to the *IESO* on how a facility should be settled.

Totalization Table Notes may include, but are not limited to, the following items:

- applying losses to a *physical meter* or a *summary meter*;
- apportioning station service losses between *metered market participants*;
- changes to a MEC, SSLA, or TLF.

## 2.3 Guidelines for Preparing Totalization Tables

### 2.3.1 Estimated Station Services

#### Non-Metered Station Services

The *metering service provider* must provide, when applicable, the *station service* factor in kW. This factor is submitted using IMO-FORM-1311 “Connection Facility Station Service – Not metered by a RWM” (Chapter 9, Section 2.1A of the *market rules*). IMO-FORM-1311 must be stamped and signed by a registered professional engineer (Professional Engineers of Ontario (PEO)). This value is entered on IMO-FORM-1310 “Totalization Table Form” for submission to the *IESO*. When processing IMO-FORM-1310 in MV-STAR, the *IESO* creates a virtual meter, with a constant, 5-minute interval value representing the *station service* factor.

The following assumptions shall be used in determining the *station service* factor:

- secondary estimated load will be calculated as the sum of the rated value of all connected loads of the equipment in-use at the station, in kW;
- if the percentage usage of the estimated load cannot be determined, the default value to be considered in calculation must be 75%;
- the *station service* load will be calculated up to the *Defined Meter Point (DMP)* as 2.0% higher than usage of the secondary estimated load; and
- the value of the *station service* factor shall be rounded to the nearest kW;
- annual checks must be performed to confirm estimate is still valid.

An example of such calculation is given below:

Total secondary connected load	27.7 kW
Usage of total secondary connected load (75%)	20.77 kW
Total primary estimated load	21.18 kW
<b>Station Service Factor</b>	<b>21 kW</b>

### 2.3.2 Estimated Station Services Using Retail Meters

The *metering service provider* can determine the *station service* factors by using a Measurement Canada approved and sealed retail meter to estimate the load.

The main items to consider when using retail meters are:

- the estimate must be based on annual consumption determined from the meter readings of the retail meter;
- the estimate must take into account losses between the location of the retail meter to the *Defined Meter Point* (DMP); 1% losses for each level of transformation is acceptable;
- the value of the *station service* factor should be rounded to the nearest kW; and
- annual readings of the retail meter must be recorded to confirm estimate is still valid; if the results are different, an updated estimate must be submitted and registered.

The *station service* factor is submitted using IMO-FORM-1311 “Connection Facility Station Service – Not metered by a RWM”. Refer to Section 2.3.1.

### 2.3.3 Apportioning Station Service Consumption

The consumption (either metered or non-metered) of *station service* transformers fed from the bus connected directly to the *IESO-controlled grid* must be allocated (excluding an *embedded load facility* or *embedded generation facility*) among all *metered market participants* associated with that *defined meter point*, based on an agreement among all affected *metered market participants*. The *IESO* enters this allocation as submitted by the relevant *metering service providers* via the “Totalization Table Form”.

*Metering service providers* can update allocations for *station service* consumption no more than once in each calendar year, or more frequently if required by the registration of a new *RWM*.

Should one or more of such *metered market participants* fail to agree on the apportionment, the *metering service provider* must use the following methods for apportioning *station service* consumption:

- the whole (100%) consumption will be allocated to the *metered market participant* associated with the *RWM* that includes that consumption; that is, the *RWM* that measures the bus; or
- when there is no bus *RWM*, the *IESO* allocates the *station service* consumption proportionally, based on the number of feeders pertaining to each *metered market participant*. Thus, a *metered market participant* with three feeders connected to a bus with a total of ten feeders must be assigned three tenths of the *station service* consumption. In such cases, the *metering service*

*provider* must enter in the totalization tables the appropriate coefficients while also providing the ratio of breakers used in the calculation.

Any disagreement with regard to the allocation of *station service* consumption must be resolved among the affected parties; if necessary, the issue may be resolved through Dispute Resolution, as described in “Market Manual 2: Market Administration, Part 2.1: Dispute Resolution”.

### 2.3.4 Apportioning Transformation Losses

The transformation losses associated with the main transformers at the *defined meter point* must be allocated among all *metered market participants* pertaining to that *defined meter point*, based on an agreement among all affected *metered market participants*. The *metering service provider* must submit this allocation on the “Totalization Table Form”.

*Metering service providers* can update allocations for transformation losses no more than once in each calendar year, or more frequently if required by the registration of a new *RWM*.

Should one or more of such *metered market participants* fail to agree on the apportionment, the following methods for allocating transformation losses must be used:

- the whole amount (100%) of transformation losses will be allocated to the *metered market participant* associated with the *RWM* that measures the bus; or
- when there is no bus *RWM*, the *IESO* will allocate the transformation losses proportionally, based on the number of feeders pertaining to each *metered market participant*. Thus, for an *metered market participant* that is associated with three feeders in a station with a total of ten feeders, the loss coefficients, originally calculated by using one of the two acceptable methods, must be adjusted as follows:
  - Method #1: coefficient “a” must be multiplied by the ratio of breakers, 3/10, while coefficient “b” must be multiplied by the inverse ratio, 10/3;
  - Method #2: coefficient “k<sub>1</sub>” must be multiplied by the inverse ratio of breakers, 10/3, while coefficient “k<sub>3</sub>” must be multiplied by the ratio, 3/10; Coefficient “k<sub>2</sub>” remains unchanged.

Regardless of the method used, the *metering service provider* must submit the coefficients already adjusted. The *metering service provider* must also provide the ratio of feeders pertaining to the *metered market participant* associated with the current *delivery point* versus the total number of feeders on the bus.

Any disagreement with regard to the way that the *IESO* has allocated the transformation losses consumption must be resolved among the affected parties; if necessary, the issue may be resolved through Dispute Resolution, as described in “Market Manual 2: Market Administration, Part 2.1: Dispute Resolution”.

Where an agreement is reached with a *metered market participant*, the method used to apportion the transmission losses shall be Method #1 or Method # 2 above depending on the loss coefficients used. Instead of the coefficient being multiplied by the ratio of breakers, the agreed amount is used. The agreed amount shall meet Chapter 9, Section 2.1A.4.2a in the *market rules* whereby the proportions provided by the each *metering service provider* shall reflect agreement amongst all applicable *metering service providers* and shall only be accepted by the *IESO* if the proportions provided by all applicable *metering service providers* sum to one.

### 2.3.5 Transmission Tariffs (TT) Customers

As established by the OEB rate order, the *transmitter* provides the *IESO* with a list of *transmission customers*, identifying the *transmission service* that applies to each: *network service*, *line connection service*, *transformation connection charge*. (Chapter 9, Section 4.1 and Chapter 10, Sections 3.1.3, 5.1.3 and 6.1.3 of the *market rules*)

Separate *delivery points* are created for *network service* and for *connection service* respectively, and totalization tables must be submitted for each. The *connection service delivery point* is used to bill either the line connection or transformation connection, or both, depending on the *transmitter's* submission. This is set by the *IESO* in the PLC system.

The rate to be charged for each service is established by an *OEB* rate order. (Chapter 10, Sections 3.4.1, 5.1.1 and 6.1.1 of the *market rules*)

### 2.3.6 Compliance Aggregation

*Market participants* may apply to aggregate *facilities* for bidding purposes. (Details of the Compliance Aggregation Program can be found in “Market Manual 1: Market Entry, Maintenance and Exit, Part 1.2: Facility Registration, Maintenance and De-Registration” and “Market Manual 4: Market Operations, Part 4.3: Real-Time Scheduling of the Physical Markets.”) If the request for aggregation is approved, the *market participant* may elect to implement the Compliance Aggregation Model.

Compliance aggregation is the functionality within MV-STAR which permits measured generation from multiple *facilities* to be aggregated and then apportioned to the *delivery points* associated with the Compliance Aggregation Model. The apportionment is performed by applying a proportionality factor based on *dispatch instructions* to the aggregation summary meter.

The Compliance Aggregation Model consists of the following elements:

#### Schedule Set

- The schedule set identifies the Shared Meter MSID and Delivery Point ID's associated with the Compliance Aggregation Model.
- Only one *delivery point* may be considered “Primary” (indicated by a ‘Y’ in the Primary column of the schedule set). The *delivery point* set to “Primary” permits full access to all underlying data of the *delivery point*. A *delivery point* set to ‘N’ in the “Primary” column of the schedule set permits access to only the calculated values at the *delivery point*.

#### Shared Meter MSID

- The Shared Meter MSID is the summary meter that is used to aggregate the generation output from all *facilities* associated with the Compliance Aggregation Model.

#### SS\_SP Meter Point

- The SS\_SP Meter Point is a notional meter point that is automatically created when the schedule set is defined in MV-STAR. A SS\_SP meter point is associated with each *delivery point* and the data contained in the SS\_SP meter point is a proportionality factor based on the *dispatch instruction* of the individual *facility*. The proportionality factor is calculated by comparing the individual energy Real Time Constrained Schedule (RTCS)

for each disaggregated delivery point to the total RTCS for the schedule set group. The proportionality factor is recorded for each 5 minute interval and is represented as a decimal percentage value. When the total RTSC is zero, the proportionality factor is distributed equally among all SS\_SP Meter Points associated with the schedule set. The sum of each interval of all SS\_SP Meter Points associated with the schedule set is 1.0.

- Due to routines in the Commercial Reconciliation System (CRS), the SS\_SP *metering data* is not available until the 6<sup>th</sup> calendar day following the *trading day*.

#### SS\_SM Summary Meter

- The SS\_SM Summary Meter is a notional summary meter that is also automatically created when the schedule set is defined in MV-STAR. The SS\_SM Summary Meter is used to disaggregate the Shared Meter MSID by the SS\_SP Meter Point. The SS\_SM Summary Meter disaggregated value is the product of the SS\_SP Meter Point and the Shared Meter MSID.
- Because the SS\_SP *metering data* is not available until 6 calendar days after the *trading day*, SS\_SM *metering data* is also only available on the 6<sup>th</sup> calendar day after the *trading day*.

The Compliance Aggregation Model makes reference to two key dates:

#### Implementation Date

- This is the date that the Compliance Aggregation Model will be entered and defined in the MV-STAR system.

#### Effective Date

- This is the date that the Compliance Aggregation Model will become active in the MV-STAR system.
- The SS\_SP *metering data* becomes available in CRS on the 6<sup>th</sup> calendar day after the *trading day*.

When developing the Compliance Aggregation Model, the following conditions shall apply:

- A *delivery point* can only be associated with one Compliance Aggregation Model.
- All *delivery points* associated with the Compliance Aggregation Model must have the same *metering service provider*.
- Once implemented, the schedule set and any component of the schedule set cannot be modified. Should changes to the schedule set be required, the Compliance Aggregation Model must be deregistered and a New Compliance Aggregation Model registered. Registration requires issuance of new *delivery points*, a Network Model build and development of a new Compliance Aggregation Model.

Once the *market participant* has received approval to proceed with Compliance Aggregation, a Compliance Aggregation Model will be developed. The Compliance Aggregation Model defines the relationship of the physical *meters*, summary meters and schedule set to the *delivery points*. The Compliance Aggregation Model will be supplied to the *market participant* for review and approval. Once accepted, the *market participant* must complete and submit IESO-FORM-1660 “Acceptance of Compliance Aggregation Model”. Using the Compliance Aggregation Model, the *metering service provider* must prepare and submit IMO-FORM-1310 “Totalization Table Form” for each *delivery point*

associated with the Compliance Aggregation Model. The “Totalization Table Form” must be received by the *IESO* at least 2 *business days* prior to the implementation date.

On the implementation date, the *IESO* will enter the totalization table into the MV-STAR system. As a result, the existing structure of the totalization table in the *metering registry* will change and these changes take effect on the start date of the *delivery point*. By completing and submitting IESO-FORM-1660, the *market participant* authorizes the *IESO* to implement the Compliance Aggregation Model and acknowledges that the current Site Registration Report for the affected *delivery points* will no longer be in effect. Typically, there is a 10-day turn-around time between the date the Compliance Aggregation Model is built in MV-STAR and the time the *IESO* receives the new signed SRR. During this interim period, the Compliance Aggregation Model represents the totalization table in the *metering registry* and is in effect.

### 2.3.7 Meter Disaggregation

*Market participants* may apply to disaggregate *facilities* for bidding purposes. If the request for disaggregation is approved, the *market participant* may elect to implement the Meter Disaggregation Model.

Meter disaggregation is the functionality within MV-STAR which enables true measured generation, derived from *registered wholesale meter(s)*, to be apportioned to two or more *delivery points* associated with the Meter Disaggregation Model. The apportionment is performed by applying a proportionality factor based on *dispatch instructions* to the aggregation summary meter.

The Meter Disaggregation Model consists of the following elements:

#### Schedule Set

- The schedule set identifies the Shared Meter MSID and Delivery Point ID’s associated with the Meter Disaggregation Model.
- Only one *delivery point* may be considered “Primary” (indicated by a ‘Y’ in the Primary column of the schedule set). The *delivery point* set to “Primary” permits full access to all underlying data of the *delivery point*. A *delivery point* set to ‘N’ in the “Primary” column of the schedule set permits access to only the calculated values at the *delivery point*.

#### Shared Meter MSID

- The Shared Meter MSID is the summary meter that aggregates the total generation output from all *facilities* associated with the Meter Disaggregation Model.

#### SS\_SP Meter Point

- The SS\_SP Meter Point is a notional meter point that is automatically created when the schedule set is defined in MV-STAR. A SS\_SP meter point is associated with each *delivery point* and the data contained in the SS\_SP meter point is a proportionality factor based on the *dispatch instruction* of the individual *facility*. The proportionality factor is calculated by comparing the individual *energy* Real Time Constrained Schedule (RTCS) for each disaggregated delivery point to the total RTCS for the schedule set group. The proportionality factor is recorded for each 5 minute interval and is represented as a decimal percentage value. When the total RTCS is zero, the proportionality factor is distributed equally among all SS\_SP Meter Points associated with the schedule set. The sum of each interval of all SS\_SP Meter Points associated with the schedule set is 1.0.

- Due to routines in the Commercial Reconciliation System (CRS), the *SS\_SP metering data* is not available until the 6<sup>th</sup> calendar day following the *trading day*.

#### SS\_SM Summary Meter

- The SS\_SM Summary Meter is a notional summary meter that is also automatically created when the schedule set is defined in MV-STAR. The SS\_SM Summary Meter is used to disaggregate the Shared Meter MSID by the SS\_SP Meter Point. The SS\_SM Summary Meter disaggregated value is the product of the SS\_SP Meter Point and the Shared Meter MSID.
- Because the *SS\_SP metering data* is not available until 6 calendar days after the *trading day*, *SS\_SM metering data* is also only available on the 6<sup>th</sup> calendar day after the *trading day*.

The Meter Disaggregation Model makes reference to two key dates:

#### Implementation Date

- This is the date that the Meter Disaggregation Model will be entered and defined in the MV-STAR system.

#### Effective Date

- This is the date that the Meter Disaggregation Model will become active in the MV-STAR system.
- The *SS\_SP metering data* becomes available in CRS on the 6<sup>th</sup> calendar day after the *trading day*.

When developing the Meter Disaggregation Model, the following conditions shall apply:

- A *delivery point* can only be associated with one Meter Disaggregation Model.
- All *delivery points* associated with the Meter Disaggregation Model must have the same *metering service provider*.
- Once implemented, the schedule set and any component of the schedule set cannot be modified. Should changes to the schedule set be required, the Meter Disaggregation Model must be deregistered and a New Meter Disaggregation Model registered. Registration requires issuance of new *delivery points*, a Network Model build and development of a new Meter Disaggregation Model.

Once the *market participant* has received approval to proceed with Meter Disaggregation, a Meter Disaggregation Model will be developed. The Meter Disaggregation Model defines the relationship of the physical *meters*, summary meters and schedule set to the *delivery points*. The Meter Disaggregation Model will be supplied to the *market participant* for review and approval. Once accepted, the *market participant* must complete and submit IESO-FORM-1665 “Acceptance of Meter Disaggregation Model”. Using the Meter Disaggregation Model, the *metering service provider* must prepare and submit IMO-FORM-1310 “Totalization Table Form” for each *delivery point* associated with the Meter Disaggregation Model. The “Totalization Table Form” must be received by the *IESO* at least 2 *business days* prior to the implementation date.

On the implementation date, the *IESO* will enter the totalization table into the MV-STAR system. As a result, the existing structure of the totalization table in the *metering registry* will change and these changes take effect on the start date of the *delivery point*. By completing and submitting IESO-FORM-1665, the *market participant* authorizes the *IESO* to implement the Meter Disaggregation Model and acknowledges that the current Site Registration Report for the affected *delivery points* will no longer be in effect.

Typically, there is a 10-day turn-around time between the date the Compliance Aggregation Model is built in MV-STAR and the time the *IESO* receives the newly signed SRR. During this interim period, the Meter Disaggregation Model represents the totalization table in the *metering registry* and is in effect.

## 2.4 Applications Associated with the Creation of Totalization Table

### 2.4.1 Participant Life Cycle (PLC)

The Participant Life Cycle (PLC) system supports facility registration and maintenance. The PLC database maintains lists and profiles of valid *market participants*, *metered market participants*, *metering service providers*, *transmitters*, *distributors*, and *delivery points*. Relationships between these entities and user permissions are also maintained in the PLC.

### 2.4.2 MV-90

MV-90 is the application that the *IESO* uses for registering *metering installations*. *Meter point* IDs that are associated with each physical *meter/recorder* are created in the registration module of MV-90, transmitted to the production module, and then exported to the MV-STAR application.

### 2.4.3 MV-STAR

MV-STAR is the application that allows the creation of “summary maps” which summate readings from various *meter point* IDs that contribute to a *delivery point* (“metered market participant account”). This application also allows the application of error correction factors and losses, as appropriate. Once processed, these allocated quantities associated with a *delivery point*, which result from “totalized” *meter* readings, are exported to the Commercial Reconciliation system. MV-STAR is the place where the *meter point* ID that identifies either a physical or a summary *meter* is associated with a *delivery point* (account), based on the totalization data provided by the *metering service provider*.

MV-STAR is the *metering database* that includes original *energy* meter readings and creates as required *energy* readings that are loss adjusted and totalized to their respective *delivery points* for *settlement* of the *IESO-administered market*.

### 2.4.4 MV-WEB

MV-WEB allows *market participants* to view and download information about market transactions. *Metering service providers* can also use MV-WEB to check the correctness of the totalization tables entered by the *IESO*, prior to signoff.

### 2.4.5 Commercial Reconciliation

Commercial Reconciliation is the *settlements/billing* system employed by the *IESO*.

## 2.5 Supporting Documentation

### 2.5.1 Submitting the Information

A standard form, “Totalization Table Form”, available on the *IESO*’s Web site as an Excel spreadsheet, must be used for the submission of totalization data for the *energy market delivery point(s)* as well as for the *TT delivery point(s)*. The Excel format allows the *metering service provider* to adjust the number of lines as fit. The *metering service provider* can start the building of the Totalization Table as soon as a new *meter point* has been created and the MEC factors and the SSLA factors have been positively reviewed by the *IESO*. However, the procedure will conclude only after the relevant *meter points* have been registered with the *IESO*. For details see “Market Manual 3: Metering, Part 3.2: Meter Point Registration and Maintenance”.

Once completed, the “Totalization Table Form” will be submitted to the *IESO* as an Excel file attached to an email message addressed to [totalizationtables@ieso.ca](mailto:totalizationtables@ieso.ca).

Details with regard to the information contained in the form, as well as the way this data is to be entered is given in Appendix B. A sample totalization is presented in Appendix C.

### 2.5.2 Confirming Correctness of the Totalization Tables

Once the *IESO* has entered the totalization tables in MV-STAR, based on the information submitted by the *metering service provider*, a “Site Registration Report”, will be generated by the *IESO*. Upon receiving the above Report from the *IESO*, the *metering service provider* must verify the data, resolve any issues with the *IESO*, sign the report and return the signed copy to the *IESO*. Upon receiving the signed “Site Registration Report” for a newly-created *delivery point*, the *IESO* will activate the billing process for the relevant *metered market participant*, as detailed in “Part 3.8: Creating and Maintaining Delivery Point Relationships”.

The *transmitter* must also sign off on the “Site Registration Report” for *transmission tariffs delivery point*.

## 2.6 Maintaining Totalization Tables

There is no maintenance process as such for totalization tables as these must be resubmitted whenever one of the following changes occur:

- creation, modification or de-registration of relevant *meter point* IDs;
- change of relevant MEC, TLF and/or SSLA;
- change in allocation of *station service* consumption or Transformation Losses; and
- change of any other item that appears on the “Totalization Table Form”. The only exception to this rule is the change of *metered market participant* or *metering service provider* for a *delivery point*. Since such changes are first captured in the PLC tool and thus reflected automatically in the relevant Totalization Table, there is no need for resubmission.

When resubmitting a totalization table, the *metering service provider* must highlight the items that have been revised using the following conventions:

- Green for creation,
- Yellow for modifications,
- Red for de-registration.

## 2.7 Site Registration Report

The Site Registration Report (SRR) reflects all the parameters of the “Totalization Table Form” submission except for the *metered market participant* and the *metering service provider* relationships. Once signed-off by the *metering service provider* (and the *Transmitter*, if applicable) the SRR becomes an official document to which the *settlement* for that *delivery point* will be invoiced. A sample SRR is presented in Appendix E.

The SRR may contain up to seven sections. Please note that there can be only one summary meter attached to a *delivery point* at any one time. We will call this summary meter THE summary meter. The seven sections are:

- 1 Report Title
  - contains the site registration report for the subject *Delivery Point* and contains the date and time when the Site Registration Report was generated by MV-STAR. The report title will be displayed on the top of every page.
- 2 Meter Tree Picture
  - a picture layout of the configuration of physical meters, summary meters, THE summary meter and the *delivery point*. The picture layout also represents *meter(s)*, summary meter(s), THE summary meter and *delivery point* that can be viewed and can be downloaded in MV-WEB.
- 3 The *delivery point* associated to THE summary meter from a start date to an end date.
  - Note: A ‘no end date’ indicates THE summary meter is active, therefore the *delivery point* is active. A specific end date will indicate that THE summary meter and the contribution from all associated meters and summary meters below have been end dated. In other words, the *delivery point* will not be settled after the specified end date.
- 4 Channel Summary for THE summary meter
  - the makeup of THE summary meter. THE summary meter will indicate:
    - Listing of channels :1), 2), 3,) 4)
    - interval length :5 or 15 minute
    - type of *meter*: Summary channel, M (Main) channel, or S (Standalone)channel
    - Unit of Measurement (UOM) :1=kwh, 3=kvarh)
    - Direction of Power Flow :I=Import/delivered/withdrawal, E=Export/received/injection
    - Voltage Code :None = no losses applied
    - : a 3 digit character

Note: Assumed Voltage, Assumed PF, CT ratio, PT ratio and ServiceType (:D=Delta, or W=Wye) are displayed only if Voltage Code exist and Method 1 losses are applied.

#### 5 Detailed Channel Information for THE Summary Meter

- Each channel of THE summary meter contains the mapping of all meters and summary meters.
- Each channel of THE summary meter will list the contributors including the parameters in 3 above.
- The plus sign indicates the metering data contribution is additive to THE summary meter's channel. A minus sign indicates the metering data contribution is subtractive to THE summary meter's channel.
- The percentage indicates the amount of *metering data* contributing to THE summary meter's channel. 100% indicates all the *metering data* is contributing where as 50% indicates only half of the *metering data* is contributing.
- The *meter* or summary meter's id.
- The channel number.
- The start date and end date. Again, an end date will indicate that the contribution from all associated meters and/or summary meters below will no longer have effective *metering data* after the specified end date. A 'null' indicates no end date.
- Interval length, type of *meter*, Unit of measurement, Power Flow direction, Voltage Code.
- An indent indicates that another layer of *meter* or summary meter is contributing.

#### 6 Voltage Code Information

- If a voltage code exists at the *meter* or summary meter, the 3 character voltage code will be listed. Underneath the listing will contain:

Precedence number—indicates the order to apply the losses

Loss Factor code ---indicates the loss factor number and type of loss factor. Fixed loss is used for MEC, DLF, TLF. Equation loss is used for method 1 and method 2.

The start date and end date. An end date of – (dash) indicates no end date.

Actual value—a Fixed loss will indicate the word Factor and then the percentage value. Method 1 will indicate I4H, I2H, V4H, V2H, and a constant. Normally, method 1 will indicate coefficients for I2H and V2H. The remaining parameters will have Zero values. Method 2 will indicate the coefficients for KVA2H, KVAH and a constant.

#### 7 Signature

- Once completed, the SRR becomes one of the official documents from which an invoice will be generated.

– End of Section –

## 3. Procedural Work Flow

The diagrams in this section represent the flow of work and information related to the Totalization Table Registration procedure between the *IESO*, the primary external participant involved in the procedure, and any other parties.

The steps illustrated in the diagrams are described in detail in Section 4.

The acronym “PWF” stands for Procedural Workflow.

**Table 3–1: Legend for Procedural Work Flow Diagrams**

<b>Legend</b>	<b>Description</b>
Oval	An event that triggers task or that completes task. Trigger events and completion events are numbered sequentially within procedure (01 to 99).
Task Box	Shows reference number, party responsible for performing task (if “other party”), and task name or brief summary of task. Reference number (e.g. 1A.02) indicates procedure number within current <i>market manual</i> (1), sub-procedure identifier, if applicable, (A), and task number (02).
Solid horizontal line	Shows information flow between the <i>IESO</i> and external parties.
Solid vertical line	Shows linkage between tasks.
Broken line	Links trigger events and completion events to preceding or succeeding task.

Labels marked TTBL-xx represent letters the *IESO* sends to the *metering service provider* at various steps in the process.

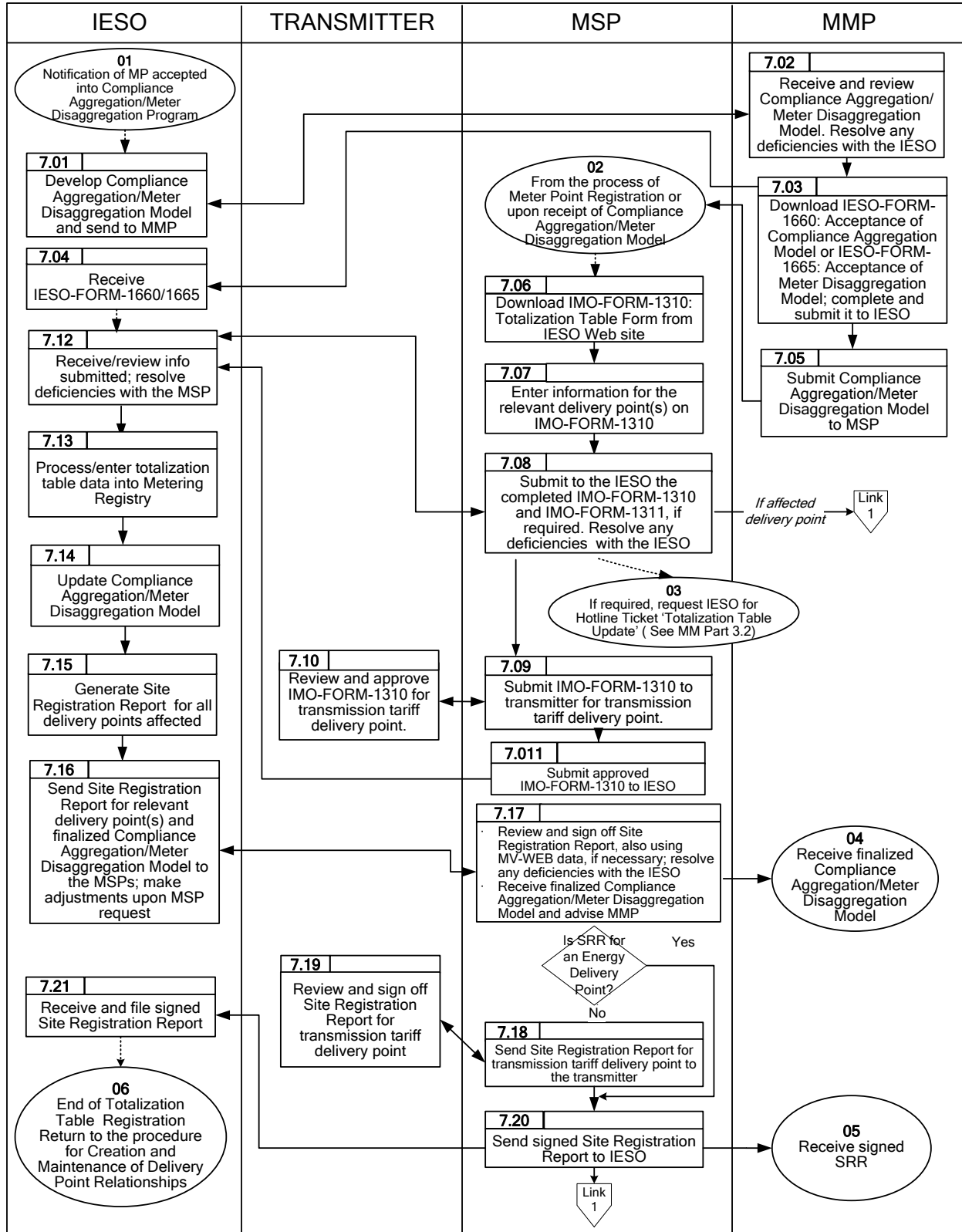
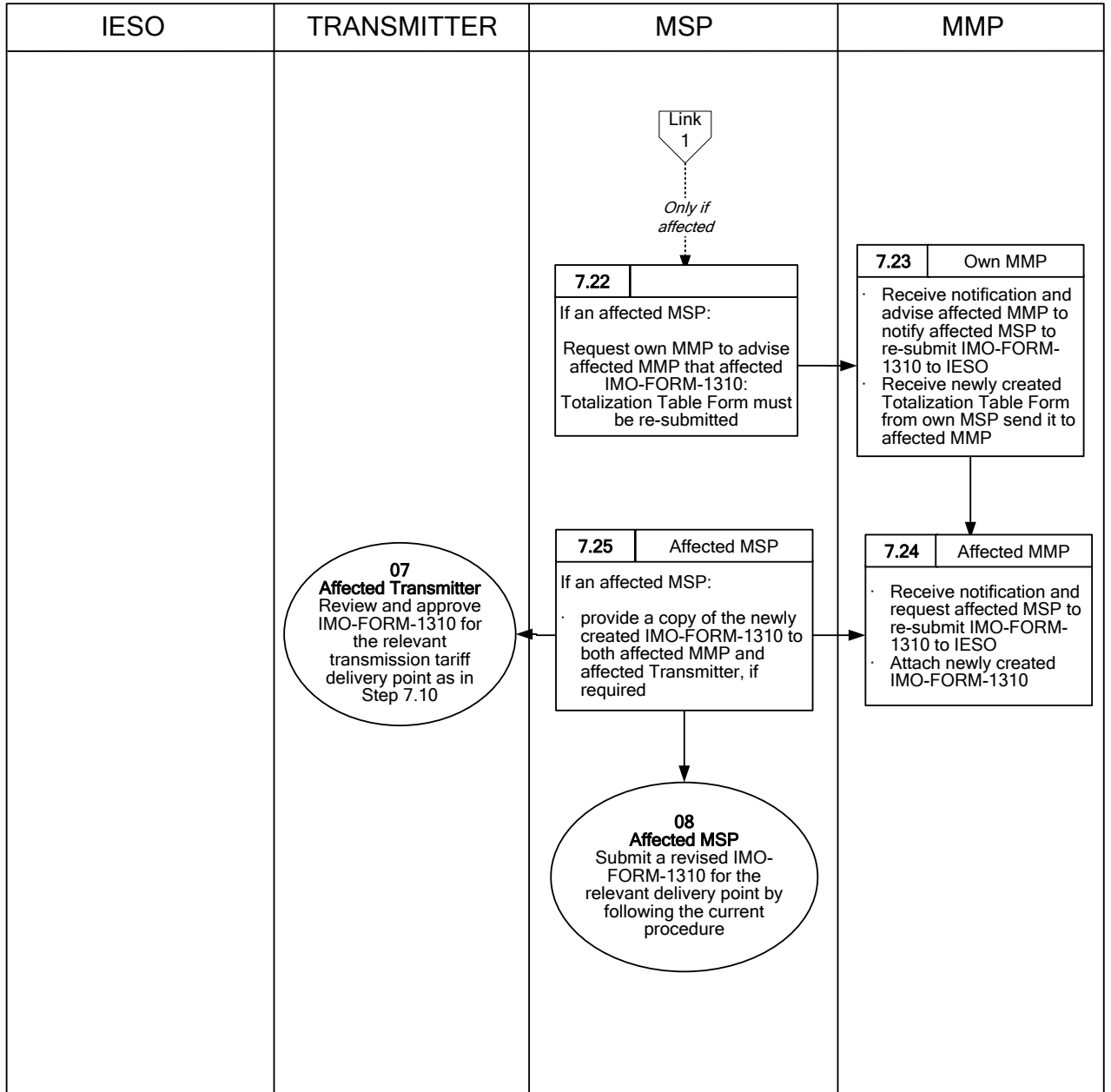

Figure 3–1: Work flow for Totalization Table Registration



**Figure 3–1: Work Flow for Totalization Table Registration (continued)**

– End of Section –

## 4. Procedural Steps

---

This section contains detail on the tasks (steps) associated with the Totalization Table Registration process. The steps described in the following table are illustrated in Figure 3-1.

The following table contains seven columns, as follows:

### **Ref**

The numerical reference to the task.

### **Task Name**

The task name as identified in Section 3.

### **Task Detail**

Detail about the task.

### **When**

A list of all the events that can trigger commencement of the task.

### **Resulting Information**

A list of the information flows that may or must result from the task.

### **Method**

The format and method for each information flow are specified.

### **Completion Events**

A list of all the circumstances in which the task should be deemed finished.

**Table 4–1: Procedural Steps for Totalization Table Registration**

<b>Ref.</b>	<b>Task Name</b>	<b>Task Detail</b>	<b>When</b>	<b>Resulting Information</b>	<b>Method</b>	<b>Completion Events</b>
7.01	Develop Compliance Aggregation/Meter Disaggregation Model and send to MMP	The <i>IESO</i> develops a Compliance Aggregation Model or a Meter Disaggregation Model and sends it to the <i>metered market participant</i> .	Upon notification that the <i>market participant</i> is accepted into the Compliance Aggregation/Meter Disaggregation Program	Compliance Aggregation Model or a Meter Disaggregation Model is created.	Email	<i>Metered market participant</i> receives a newly-created Compliance Aggregation Model or a Meter Disaggregation Model.
7.02	Receive and review the Compliance Aggregation/Meter Disaggregation Model. Resolve any deficiencies with the <i>IESO</i>	The <i>metered market participant</i> receives the Compliance Aggregation Model or a Meter Disaggregation Model and reviews the information. Any deficiencies identified must be resolved with the <i>IESO</i> .	After Step 7.01	Issue resolution, if any.	Mail, fax, e-mail or Telephone.	Agreed-upon Compliance Aggregation Model or a Meter Disaggregation Model
7.03	Download IESO-FORM-1660 “Acceptance of Compliance Aggregation Model” or IESO-FORM-1665 “Acceptance of Meter Disaggregation Model” from <i>IESO</i> Web site.  Complete and submit it to the <i>IESO</i> .	Using the <i>IESO</i> Web site, the <i>metered market participant</i> downloads, completes and submits IESO-FORM-1660 “Acceptance of Compliance Aggregation Model” or IESO-FORM-1665 “Acceptance of Meter Disaggregation Model” to the <i>IESO</i> .	Upon completion of Step 7.02	Completed and signed acceptance of the Compliance Aggregation Model or a Meter Disaggregation Model.	Email or fax	Submitted IESO-FORM-1660 or IESO-FORM-1665

**Table 4–1: Procedural Steps for Totalization Table Registration**

<b>Ref.</b>	<b>Task Name</b>	<b>Task Detail</b>	<b>When</b>	<b>Resulting Information</b>	<b>Method</b>	<b>Completion Events</b>
7.04	Receive IESO-FORM-1660/1665	The <i>IESO</i> receives IESO-FORM-1660 with the accepted Compliance Aggregation Model or IESO-FORM-1665 with the accepted Meter Disaggregation Model.	After the <i>metered market participant</i> sends IESO-FORM-1660 or 1665 to the <i>IESO</i>	Accepted Compliance Aggregation Model or Meter Disaggregation Model	Email	Signed IESO-FORM-1660 or IESO-FORM-1665
7.05	Submit Compliance Aggregation/Meter Disaggregation Model to <i>metering service provider</i>	<i>Metered market participants</i> must submit the agreed-upon Compliance Aggregation/Meter Disaggregation Model to their own <i>metering service provider</i> . Their <i>metering service provider</i> uses this model to build the relevant totalization table.	Upon acceptance of the Compliance Aggregation Model or the Meter Disaggregation Model.	The <i>metering service provider</i> acquires the Compliance Aggregation Model or Meter Disaggregation Model from the <i>metered market participant</i> .	Email/fax/mail	The <i>metering service provider</i> receives the agreed-upon Compliance Aggregation Model or Meter Disaggregation Model
7.06	Download IMO-FORM-1310 “Totalization Table Form” from <i>IESO</i> Web site.	<i>Metering service provider</i> downloads IMO-FORM-1310 “Totalization Table Form” from the <i>IESO</i> Web site.	From the process of <i>meter point</i> Registration (For newly created <i>delivery points</i> , all associated <i>meter point</i> IDs must have been registered.)  or  upon receiving a Compliance Aggregation/Meter Disaggregation Model from the <i>metered market participant</i>		<i>IESO</i> Web site.	“Totalization Table Form” downloaded.

**Table 4–1: Procedural Steps for Totalization Table Registration**

Ref.	Task Name	Task Detail	When	Resulting Information	Method	Completion Events
7.07	Enter information for the relevant <i>delivery point(s)</i> on IMO-FORM-1310	<p><i>Metering service provider</i> enters required information on the “Totalization Table Form”, as detailed in Appendix B.</p> <p>All physical <i>meters</i> used as contributors must have been registered with the <i>IESO</i>. If the <i>metered market participant</i> is also an MMPT that feeds an <i>embedded generator(s)</i> built after 1998 and that do not participate in the <i>energy market</i>, the MMPT must ensure that the associated <i>meters</i> that will be used for <i>transmission tariffs</i> only are properly registered with the <i>IESO</i>.</p>	After Step 7.06.			Totalization Table completed and signed.

**Table 4–1: Procedural Steps for Totalization Table Registration**

<b>Ref.</b>	<b>Task Name</b>	<b>Task Detail</b>	<b>When</b>	<b>Resulting Information</b>	<b>Method</b>	<b>Completion Events</b>
7.08	Submit to the <i>IESO</i> the completed IMO-FORM-1310 for the relevant <i>delivery point(s)</i> Resolve any deficiencies with the <i>IESO</i> .	<p><i>Metering service provider</i> sends the completed “Totalization Table Form” for the relevant <i>delivery point(s)</i> via e-mail. Any deficiencies identified by the <i>IESO</i> must be remedied (see also Step 7.09).</p> <p>If this task is strictly a change to the totalization table, then request a ‘Totalization Table Update’ Hotline Ticket from the <i>IESO</i>. Refer to the Hotline Ticket process described in “Market Manual 3: Metering, Part 3.2: Meter Point Registration and Maintenance”.</p> <p>If a value is required on IMO-FORM-1310 for Non-metered Station Service, then the <i>metering service provider</i> for the relevant <i>delivery point</i> downloads, completes and submits IMO-FORM-1311: “Connection Station Service – Not metered by a RWM”.</p>	After Step 7.07.	<p>Completed “Totalization Table Form”.</p> <p>If required, completed IMO-FORM-1311: “Connection Station Service – Not metered by a RWM”.</p>	<p>Totalization table by e-mail (<a href="mailto:totalizationtable@ieso.ca">totalizationtable@ieso.ca</a>).</p> <p>Rest of documents by mail or fax.</p>	<p>Signed “Totalization Table Form” sent to the <i>IESO</i>; if appropriate also submit the SLD and “SLD-Submission Form”.</p> <p>Submitted “Connection Station Service – Not metered by a RWM”, if required.</p>
7.09	Submit IMO-FORM-1310 to <i>transmitter</i> for <i>transmission tariffs delivery point</i> .	<i>Metering service provider</i> sends the “Totalization Table Form” to the <i>transmitter</i> for review and approval.	After Step 7.08.			Signed “Totalization Table Form” sent to the <i>transmitter</i> .

**Table 4–1: Procedural Steps for Totalization Table Registration**

Ref.	Task Name	Task Detail	When	Resulting Information	Method	Completion Events
7.10	Review and approve IMO-FORM-1310 for <i>transmission tariffs delivery point</i> .	The <i>transmitter</i> reviews and approves the “Totalization Table Form” and resolves any deficiencies with the <i>metering service provider</i> . The <i>transmitter</i> returns the approved “Totalization Table Form” to the <i>metering service provider</i> once approved.	After Step 7.09.			<i>Transmitter</i> sends approved “Totalization Table Form” to <i>metering service provider</i> .
7.11	Submit approved IMO-FORM-1310 to <i>IESO</i> .	After receiving the approved “Totalization Table Form” from the <i>transmitter</i> , the <i>metering service provider</i> submits it to the <i>IESO</i> via e-mail.		Completed “Totalization Table Form”.	Totalization table by e-mail ( <a href="mailto:totalizationtables@ieso.ca">totalizationtables@ieso.ca</a> ).	Signed “Totalization Table Form” sent to the <i>IESO</i> .
7.12	Receive/review info submitted; resolve deficiencies with the <i>metering service provider</i> .	<i>IESO</i> receives documentation and reviews the information. Any deficiencies identified must be resolved with the <i>metering service provider</i> .	After Step 7.08 and Step 7.11.	Issue resolution, if any.	Mail, fax, e-mail or Telephone.	
7.13	Process/enter totalization table data into <i>metering registry</i> .	<i>IESO</i> processes the totalization table information received and enters it into MV-STAR ( <i>metering registry</i> ).	After Step 7.12.	<i>Metering registry</i> complete with totalization table information for the relevant <i>delivery point</i> . If required, <i>meter point</i> records also updated.		The <i>metering registry</i> is current with the submitted information.
7.14	Update Compliance Aggregation/Meter Disaggregation Model	Update the Compliance Aggregation Model or the Meter Disaggregation Model in accordance with the MV-STAR defined schedule set.	After Step 7.13	If required, the Compliance Aggregation/Meter Disaggregation Model is updated.		Finalized Compliance Aggregation/Meter Disaggregation Model

**Table 4–1: Procedural Steps for Totalization Table Registration**

<b>Ref.</b>	<b>Task Name</b>	<b>Task Detail</b>	<b>When</b>	<b>Resulting Information</b>	<b>Method</b>	<b>Completion Events</b>
7.15	Generate “Site Registration Report” for all <i>delivery points</i> affected.	<i>IESO</i> generates the Site Registration Report that will enable the <i>metering service provider</i> to assert whether the totalization table(s) has been properly entered into the <i>metering registry</i> .		“Site Registration Report”.		“Site Registration Report” generated.
7.16	Send “Site Registration Report” for all relevant <i>delivery points</i> and finalized Compliance Aggregation/Meter Disaggregation Model to the <i>metering service provider</i> ; make adjustments upon <i>metering service provider</i> request.	<i>IESO</i> sends “Site Registration Report” for all relevant <i>delivery points</i> and the finalized Compliance Aggregation Model or Meter Disaggregation Model to the <i>metering service provider</i> . A due date is included for the return of the approved Site Registration Report.  <i>IESO</i> resolves any deficiencies with the <i>metering service provider</i> and re-enters data if necessary.			Email or fax.	“Site Registration Report” sent to the <i>metering service provider</i> .

**Table 4–1: Procedural Steps for Totalization Table Registration**

Ref.	Task Name	Task Detail	When	Resulting Information	Method	Completion Events
7.17	<ul style="list-style-type: none"> <li>Review and sign off Site Registration Report, also using MV-WEB data, if necessary; resolve any deficiencies with the IESO.</li> <li>Receive finalized Compliance Aggregation/Meter Disaggregation Model and advise metered market participant.</li> </ul>	<p>The <i>metering service provider</i> reviews and signs the “Site Registration Report” MV-WEB may also be consulted for readings at various <i>meter points</i>.</p> <p>The <i>metering service provider</i> receives the finalized Compliance Aggregation Model or Meter Disaggregation Model and must send it to the <i>metered market participant</i>.</p>		Issue resolution, if necessary.	E-mail or telephone.	Site Registration Report is signed.
7.18	Send Site Registration Report for <i>transmission tariffs delivery point</i> to the <i>transmitter</i> .	The <i>metering service provider</i> sends the “Site Registration Report” for <i>transmission tariffs delivery point</i> to the <i>transmitter</i> for review and sign off or proceeds to step 7.19 if the Site Registration Report is an <i>Energy Delivery Point</i> .		Site Registration Report.		Site Registration Report sent to <i>transmitter</i> for a <i>transmission tariffs delivery point</i> .
7.19	Review and sign off “Site Registration Report” for <i>transmission tariff delivery point</i> .	The <i>transmitter</i> reviews and approves the “Site Registration Report” and resolves any deficiencies with the <i>metering service provider</i> . The <i>transmitter</i> returns the signed “Site Registration Report” to the <i>metering service provider</i> once approved.	By the due date indicated on the Site Registration Report			Signed “Site Registration Report” returned to <i>metering service provider</i> .

**Table 4–1: Procedural Steps for Totalization Table Registration**

<b>Ref.</b>	<b>Task Name</b>	<b>Task Detail</b>	<b>When</b>	<b>Resulting Information</b>	<b>Method</b>	<b>Completion Events</b>
7.20	Send signed “Site Registration Report” to <i>IESO</i> .	Upon completing Step 7.16 and/or step 7.18/7.17, <i>metering service provider</i> sends signed “Site Registration Report” for <i>energy delivery point</i> and/or <i>transmission tariffs delivery point</i> and returns it (them) to the <i>IESO</i> .	By the due date indicated on the Site Registration Report	Signed “Site Registration Report”.	Email to <a href="mailto:SRR@ieso.ca">SRR@ieso.ca</a>	“Site Registration Report” returned to the <i>IESO</i> .
7.21	Receive and file signed “Site Registration Report”.	<i>IESO</i> receives signed “Site Registration Report” and files it in the metering records. This is the end of the process if the <i>metered market participant</i> associated with the <i>delivery point</i> does not have affected <i>meter points</i> and if no other totalization tables are affected. Otherwise, the <i>IESO</i> must ensure that all affected totalization tables have been signed off by the relevant <i>metering service providers</i> and that the relevant information (start dates, end dates, etc.) is consistent. If there are affected <i>meter points</i> , the <i>IESO</i> makes sure that affected <i>metered service provider(s)</i> has also submitted its revised totalization table, as all related tables must have the same starting date and time.				End of Totalization Table Registration. Return to the procedure, “Part 3.8: Creating and Maintaining Delivery Point Relationships”.

**Table 4–1: Procedural Steps for Totalization Table Registration**

Ref.	Task Name	Task Detail	When	Resulting Information	Method	Completion Events
7.22	If an affected <i>metering service provider</i> , request own <i>metered market participant</i> to advise affected <i>metered market participant</i> that IMO-FORM-1310 “Totalization Table Form” must be re-submitted.	If affected <i>meter points</i> , the <i>metering service provider</i> communicates to its own <i>metered market participant</i> that an affected <i>metered market participant</i> must inform the affected <i>metering service provider</i> to re-submit all affected totalization tables.	After Step 7.19, if an affected <i>metering service provider</i> is involved.			Own <i>metered market participant</i> notified.
7.23	<ul style="list-style-type: none"> <li>• Receive notification and advise affected <i>metered market participant</i> to notify affected <i>metering service provider</i> to re-submit IMO-FORM-1310 to <i>IESO</i>.</li> <li>• Receive newly created “Totalization Table Form” from own <i>metering service provider</i> and send it to affected <i>metered market participant</i></li> </ul>	<p>Own <i>metered market participant</i> receives the notification and advises the affected <i>metered market participant</i> to notify the affected <i>metering service provider</i> to re-submit IMO-FORM-1310 to the <i>IESO</i>. All affected <i>meter points</i> must have a signed “Totalization Table Form” to complete the totalization table for the <i>delivery points</i>.</p> <p>The <i>metered market participant</i> receives the newly created “Totalization Table Form” from own <i>metering service provider</i> and sends it to the affected <i>metered market participant</i>.</p>	After receiving notification and a new “Totalization Table Form” from own <i>metering service provider</i>			Affected <i>metered market participant</i> notified.

**Table 4–1: Procedural Steps for Totalization Table Registration**

<b>Ref.</b>	<b>Task Name</b>	<b>Task Detail</b>	<b>When</b>	<b>Resulting Information</b>	<b>Method</b>	<b>Completion Events</b>
7.24	<p>Affected MMP:</p> <ul style="list-style-type: none"> <li>• Receive notification and request affected <i>metering service provider</i> to re-submit IMO-FORM-1310 to <i>IESO</i></li> <li>• Attach newly created IMO-FORM-1310</li> </ul>	<p>The <i>metered market participant</i> receives the notification from the originating <i>metered market participant</i> and requests the affected <i>metering service provider</i> to re-submit a new “Totalization Table Form” to the <i>IESO</i>.</p> <p>The affected <i>metered market participant</i> receives the newly created “Totalization Table Form” from the originating <i>metering service provider</i> and attached it to the request to the affected <i>metering service provider</i>.</p>	After 7.22.			Affected <i>metering service provider</i> notified.
7.25	<p>Affected MSP:</p> <p>Provide a copy of the newly created IMO-FORM-1310 to both affected <i>metered market participant</i> and affected <i>transmitter</i>, if required.</p>	The affected <i>metering service provider(s)</i> receives request and undertakes the same procedure described in this document for re-submitting Totalization Table for the relevant <i>delivery points</i> .	Upon notification from affected <i>metered market participant</i>			Totalization table created by affected <i>metering service provider</i>

–End of Section –

## Appendix A: Forms

---

This appendix contains a list of forms used in the Totalization Table Registration procedure, which are available on the *IESO* Web site ([www.ieso.ca](http://www.ieso.ca)). The forms included are listed in the table below.

<b>Form Name</b>	<b>Form Number</b>
Totalization Table Form	IMO-FORM-1310 (Excel spreadsheet)
Connection Facility Station Service – Not Metered by an RWM	IMO-FORM-1311
Acceptance of Compliance Aggregation Model	IESO-FORM-1660
Acceptance of Meter Disaggregation Model	IESO-FORM-1665

– End of Section –



# Appendix B: Guidelines for Completing the Totalization Table Form

---

## General Overview

The information submitted to the *IESO* relates to physical *meters* that contribute to the *settlement* at a specific *delivery point*. These physical *meters* are then used by the *IESO* as contributors to summary (virtual *meters*) associated with the *delivery point*. In the enduring stage, the *metering service provider* will, however, submit complete totalization tables, ready for input into MV-STAR. The *metering service provider* must submit the information, electronically, on an Excel spreadsheet that can be downloaded from the *IESO* Web site. The standard spreadsheet form contains three distinct areas: general information (at the top), *energy market*, and *transmission tariffs*.

The general information area, at the top of each form, includes the following fields:

- **Facility Name:** enter the name of *facility* as recorded on the SLD and the “SLD-Submission Form” submitted for *meter point* registration;
- **Effective Date:** enter the estimated date when *settlement* at the *delivery point* must start; note that the real date for starting *settlements* is the date when *metered market participant* relationships for *delivery point* are accepted by the *IESO*, see “Market Manual 3: Metering, Part 3.8: Creating and Maintaining Delivery Point Relationships”;
- **Metering Service Provider ID:** enter the ID assigned to the *metering service provider* during *metering service provider* registration;
- **Prepared by:** enter the name of *metering service provider’s* staff who prepared the information;
- **Ratio of Breakers for (enter the metered market participant name and #):** enter the number of breakers pertaining to each *metered market participant* involved and the total number of feeder breakers; and
- **Non-Metered Station Service (kW):** enter the value previously submitted as per Section 2.3.1.

The detailed information to be entered in **Area A: *energy market*** includes the following:

- **Metered Market Participant:** enter the *metered market participant #* , as above;
- **Delivery Point ID (energy):** enter the *delivery point* at which the above *metered market participant* is settled, as recorded on the SLD and the “SLD-Submission Form” submitted for *meter point* registration;
- **Summary 1:** to be completed by *IESO*, for now;
- **Summary 2:** to be completed by *IESO*, for now;
- **Meter Point ID:** enter the ID of the physical *meter* (contributor) as assigned during *meter point* registration or enter none for *station service*;

- **Channel No:** enter the channel number of the physical *meter*; only kWh and kVARh channels are required;
- **Operator + or -:** enter “+” if the reading of the *meter* is to be added or “-” if subtracted;
- **U of M** enter the unit of measure (kWh or kVARh);
- **Energy Flow Direction:** enter the direction of *energy* (“DEL” for delivered, “REC” for received);
- **Description of Measured Circuit:** identify the physical location of the *meter* as specified on the relevant SLD submitted during the process of *meter point* registration (Ex: Pine TS-T4);
- **Ratio (scaling):** leave blank for 100% allocation of *metering data*. A value of .5 would indicate to allocate 50% of the *metering data*;
- **MEC:** enter MEC value as per Section 2.2.4;
  - **Assumed Voltage<sup>1</sup>:** enter value of assumed secondary voltage;
  - **Assumed PF\*:** enter value for the assumed power factor, two decimal digits are required;
  - **Service Type\*:** enter “D” for 3-wire, delta service or “W” for 4-wire, wye service;
  - **CT Ratio\*:** enter the current transformer’s ratio in use;
  - **PT Ratio\*:** enter the voltage transformer’s ratio in use;
- **Coefficients for Transformation Losses and/or Radial Line,** as follows (enter already adjusted values, as per Section 2.2.5):
 

**Transformation:**

  - a ( $V^2$ )
  - b ( $I^2$ )

**Radial line:**

  - e ( $V^2$ )
  - f ( $I^2$ )
- **Coefficients for Transformation Losses and/or Radial Line** (for three winding transformers, enter already adjusted values, as per Section 2.2.5) as follows:
 

**Transformation:**

  - $k_1$
  - $k_2$
  - $k_3$

**Radial line:**

  - $k_1$
  - $k_2$
  - $k_3$

---

<sup>1</sup> Required only when loss coefficients “a” and “b” and/or “e” and “f” are used.

- **TLF (for embedded metered market participants only):** enter Total Loss Factor as per Section 2.2.6.

The detailed information to be entered in **Area B: *transmission tariffs*** includes the following:

- **MMPT Name:** enter the *Market Participant* name and number who is the *transmission customer*;
- **MMPT#:** enter the *Market Participant #* , as above;
- **DP ID:** enter the *TT delivery point* IDs, as submitted on the SLD and “SLD-Submission Form”;
- **Summary 3:** to be completed by the *IESO*, for now;
- **Summary 4:** to be completed by the *IESO*, for now;
- **Meter Point ID:** enter the ID of the physical *meter* (contributor) as assigned during *meter point* registration or enter none for *station service*;
- **Channel No:** enter the channel number of the physical *meter*; only kWh and kVARh channels are required;
- **Operator + or -:** enter “+” if the reading of the *meter* is to be added or “-” if subtracted;
- **U of M** enter the unit of measure (kWh or kVARh);
- **Energy Flow Direction:** enter the direction of *energy* (“DEL” for delivered, “REC” for received);
- **Description of Measured Circuit:** identify the physical location of the *meter* as specified on the relevant SLD (Ex: Pine TS-T4).

The rest of the fields in the *transmission tariffs* area (the hatched columns) must be filled only if the associated *meters* (*meter points*) are used exclusively for *transmission tariffs*; otherwise, there is no need to populate them. If the *meter point* ID is the same as for the *energy market*, then all the hatched cell information will apply.

However, this information (such as SSLA, MEC and TLF factors) can be added at the MSP’s discretion.

**Note:** *Meter point* IDs pertaining to *meters* that will be used for TT calculations, only, must be marked by an asterisk. Such *meters* are associated with *embedded generators* built after 1998 and that do not participate in the *energy market*. It is the responsibility of the host MMPT to ensure that such *meters* are properly registered with the *IESO*.

– End of Section –



# Appendix C: Example of Totalization

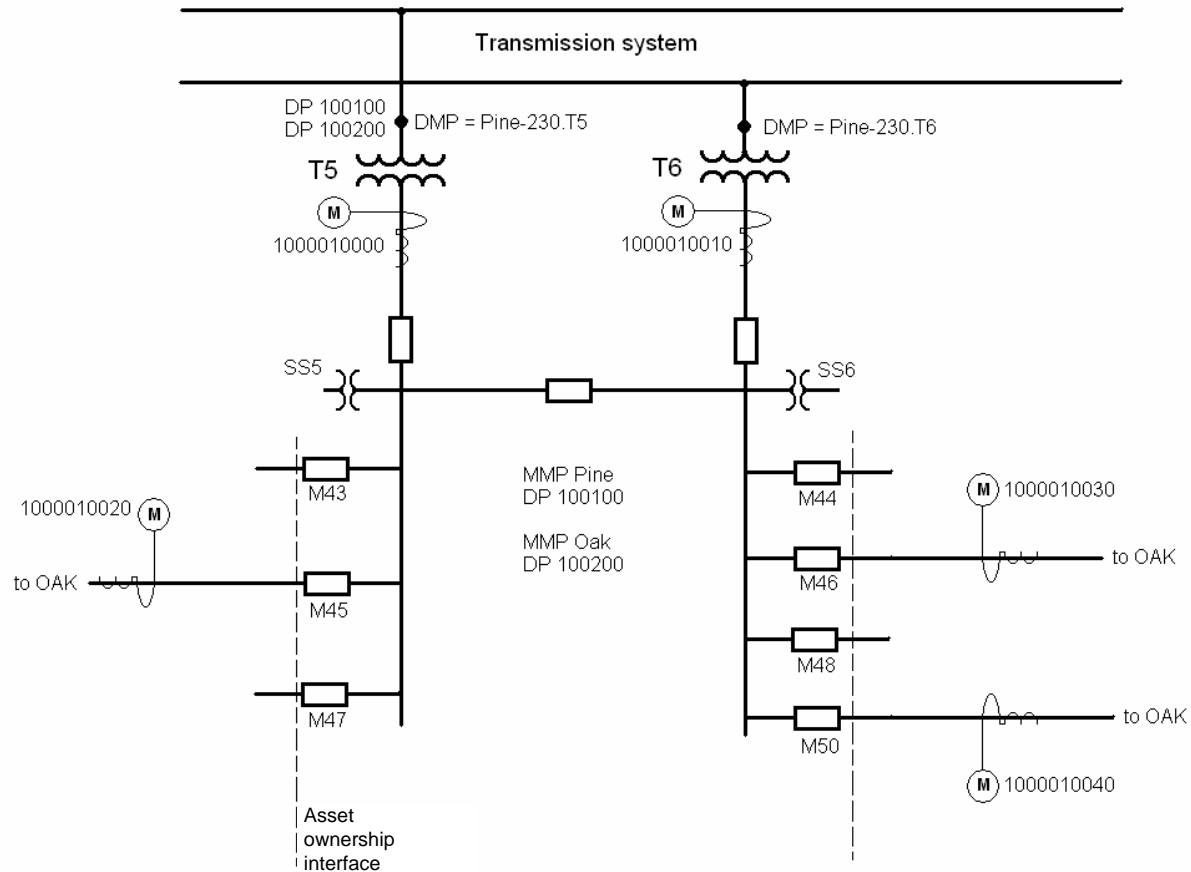

**Figure C-1: Single Line Diagram for Pine TS T5/T6**

**Table C-1: Totalization Table Form**



**TOTALIZATION TABLE FORM**

Facility Name	Pine TS
Effective Date	01-Oct-00
MSP ID	1000
Prepared By (MSP)	Tom Jones
IESO Build By	

Breaker Ratio	T <sub>5</sub>		T <sub>6</sub>		T <sub>45</sub>	
	MMP Feeders	Total Feeders T5/T6	MMP Feeders	Total Feeders	MMP Feeders	Total Feeders
	MMP1: Pine	4	7			
MMP2: Oak	3	7				

Non-metered Station Service (kW) SS5+SS6 = 15kW

**A. ENERGY MARKET**

Full SSLA			
Date		k1	k2
01-Oct-00	T5-T6	0.0192	-0.173
			104.41

MMP #	DP ID	Summary 1	Summary 2	Meter Point ID	Channel No.	Operator (+ or -)	UoM	Energy Flow Direction	Description of Measured Circuit	Ratio (3 dec.)	MEC	Assumed Voltage	Assumed Ratio	Service Type	CT Ratio	PT Ratio	Transformation		Radial Line			TLF			
																	a(V <sup>2</sup> )	b(I <sup>2</sup> )	e(V <sup>2</sup> )	f(I <sup>2</sup> )	k <sub>1</sub>		k <sub>2</sub>	k <sub>3</sub>	
1	100100			100001000	1	+	kWh	del	T5									0.0192	-0.173	104.410					
			100100C99	100001000	2	+	kVARh	del	T5																
				100001000	3	+	kWh	rec	T5																
				100001000	4	+	kVARh	rec	T5																
				1000010010	1	+	kWh	del	T6											0.0192	-0.173	104.410			
				1000010010	2	+	kVARh	del	T6																
				1000010010	3	+	kWh	rec	T6																
				1000010010	4	+	kVARh	rec	T6																
				1000010020	1	-	kWh	del	M 45											0.0448	-0.173	44.747			
				1000010020	2	-	kVARh	del	M 45																
			100100EE	100200E	1000010020	3	-	kWh	rec	M 45															
					1000010020	4	-	kVARh	rec	M 45															
					1000010030	1	-	kWh	del	M46										0.0448	-0.173	44.747			
					1000010030	2	-	kVARh	del	M46															
					1000010030	3	-	kWh	rec	M46															
					1000010030	4	-	kVARh	rec	M46															
					1000010040	1	-	kWh	del	M50										0.0448	-0.173	44.747			
					1000010040	2	-	kVARh	del	M50															
					1000010040	3	-	kWh	rec	M50															
					1000010040	4	-	kVARh	rec	M50															
			20	1	-	kWh	del	SS_Pine	0.429																

**Table C-1: Totalization Table Form (continued)**

2	100200	100200C99	1000010020	1	+	kWh	del	M45										0.0448	-0.173	44.747								
			1000010020	2	+	kVARh	del	M45																				
			1000010020	3	+	kWh	rec	M45																				
			1000010020	4	+	kVARh	rec	M45																				
			1000010030	1	+	kWh	del	M46												0.0448	-0.173	44.747						
			1000010030	2	+	kVARh	del	M46																				
			100200E	1000010030	3	+	kWh	rec	M46																			
				1000010030	4	+	kVARh	rec	M46																			
				1000010040	1	+	kWh	del	M50												0.0448	-0.173	44.747					
				1000010040	2	+	kVARh	del	M50																			
				1000010040	3	+	kWh	rec	M50																			
				1000010040	4	+	kVARh	rec	M50																			
					20	1	+	kWh	del	SS_Pine	0.429																	



# Appendix D: Metering - Settlement Principles

---

## Metering - Settlement Principles

This Appendix provides examples of the application of principles utilized by the *IESO* in settling the wholesale market. These examples are not intended to be exhaustive of circumstances that may arise and may not reflect *market participants'* commercial arrangements or agreements with other *market participants* or other third parties. If *market participants* have particular requirements or encounter circumstances not covered in the examples, or if *market participants* believe the examples are not appropriate, they should contact the *IESO* prior to submission of the totalization table. *Metered market participants* and their *metering service providers* are responsible for ensuring that the application of the principles are appropriate to their situation.

*Metered market participants* are also responsible for ensuring that their respective *OEB* approved loss factors such as the TLF are applied in a manner consistent with their respective rate orders.

The *IESO* is not responsible or liable for any commercial arrangements or other agreements between *market participants* such as *MMPs*, *MSPs*, *transmitters*, *distributors* and *generators*, or between *market participants* and other third parties. In addition, as noted above, the examples in this Appendix may not reflect these arrangements or agreements. If *market participants* have particular commercial arrangements or agreements not covered in the examples or where they believe the examples are not appropriate, they should contact the *IESO* prior to submission of the totalization table.

### A. General Arrangement - Note Variations of Layout Used in all Cases

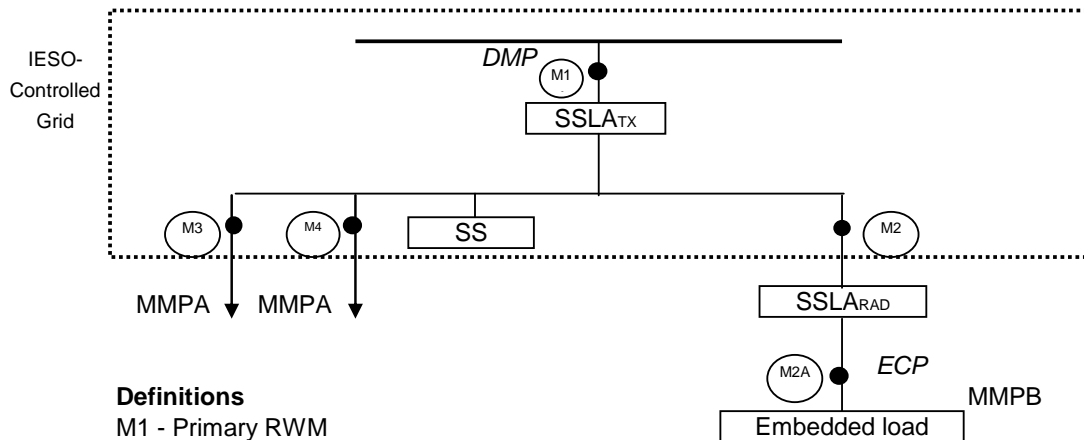

#### Definitions

M1 - Primary RWM

M2A - Embedded RWM

M2, M3 & M4 - RWM

● defines the CT location (the point of measurement)

SS - station service (note location may vary)

SSLA<sub>TX</sub> - site specific loss adjustment in kWh - transformer

SSLA<sub>RAD</sub> - site specific loss adjustment in kWh - radial line loss

where there is sharing of losses and station service, MMPA share Y, MMPB share Z, then

$$SSLA_{TX} = SSLAY + SSLAZ$$

$$SS = SSY + SSZ$$

ECP - embedded connection point

TLF - total loss factor (per OEB)

DMP - defined meter point

TT - transmission tariff

Agreement - means an SSLA<sub>TX</sub> and SS allocation agreement between MMPs

No agreement - means Market Rules Ch 9 default values for SSLA<sub>TX</sub> and SS

MMP - metered market participant, may be A, B etc

Tap - means a physical line tap for load, whether temporary, or permanent, or emergency

- Notes:
1. SSLAY and SSLAZ are loss component values (kWh) calculated from application of Y & Z to the loss code for each interval and represents their share of the losses.
  2. SSY and SSZ is the application of the ratios of Y and Z to the total station service load, also in kWh
  3. The ECP is equivalent to the DMP for an embedded facility. ECP is used for simplicity.
  4. The transmission tariffs are strictly based on the applicable Ontario Transmission Rate Schedules.
  5. The assumption is the TLF includes the station service load
  6. An embedded participant has a TLF but no station service load or transmission charge.
  7. Directly connected to a HONI Transformer Station (TS) means the LDC feeder is directly connected to the TS bus inside the fence - no TLF, and the LDC is the TT customer
  8. An embedded participant is defined as per the Market Rules
  9. A participant is either embedded or directly connected, not both.
  10. A directly connected participant is defined by the transmission connection agreement.
  11. Market Participants shall ensure that their TLFs are being applied appropriately. The IESO is not party to the individual LDCs TLF calculations and is not responsible for their misapplication.
  12. The transmitter is responsible for the station service metering
  13. The participant that owns the majority of the feeders is responsible for the loss calculation. unless they cause a calculation to be performed.
  14. The TLF is used to settle both the energy consumed and transmission charges.
  15. The principles are based on TLFs not including any measurement error correction (MEC). These are applied separately to the meter reading.

**1. High Side Meter**

**Assumption:** MMPA is the only participant

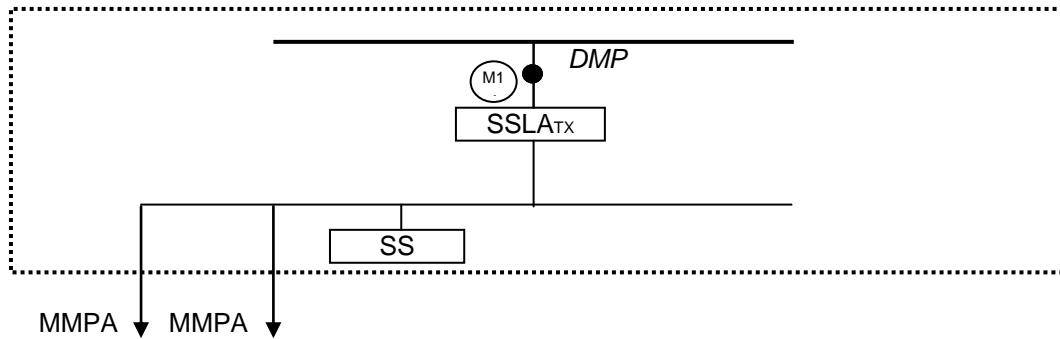

1.1 Total<sub>energy</sub> = M1      M1 captures all losses and station service  
 MMPA<sub>energy</sub> = M1  
 MMPA<sub>TT</sub> = M1

**2 a). High Side Meter + MMPB Directly Connected to the TS bus with feeder meter**

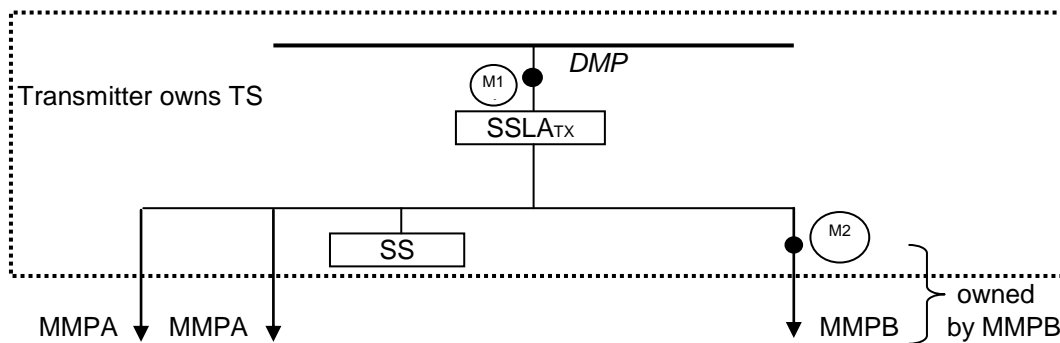

MMPA and MMPB are directly connected to the TS bus inside the fence  
 MMPA and MMPB are transmission customers

**2 a).1 Agreement on losses**

MMPA<sub>energy</sub> = M1 - (M2 + SSZ + SSLAZ)  
 MMPA<sub>TT</sub> = M1 - (M2 + SSZ + SSLAZ)  
 MMPB<sub>energy</sub> = M2 + SSZ + SSLAZ  
 MMPB<sub>TT</sub> = M2 + SSZ + SSLAZ

**2 a).2 No Agreement on losses (MMPB gets zero losses)**

SSZ=0, SSLAZ=0  
 MMPA<sub>energy</sub> = M1 - M2  
 MMPA<sub>TT</sub> = M1 - M2  
 MMPB<sub>energy</sub> = M2  
 MMPB<sub>TT</sub> = M2

Notes: 1. MMPB provides the loss calculation

## 2 b). Bus Meter + MMPB Directly Connected to the TS bus with feeder meter

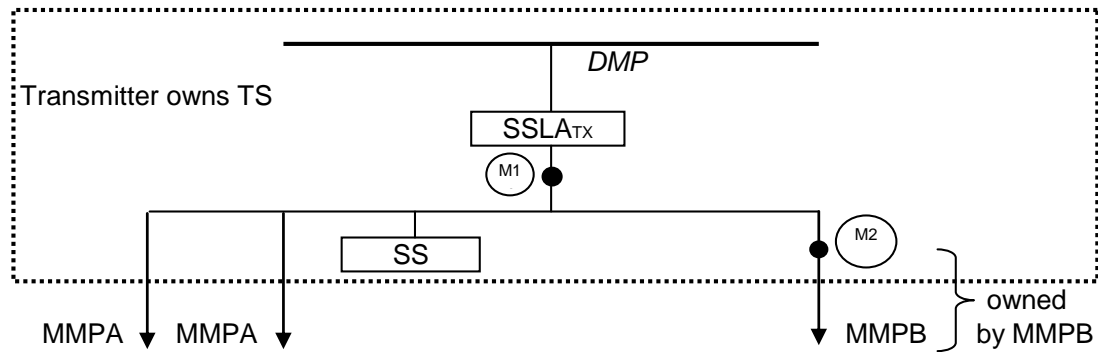

MMPA and MMPB are directly connected to the TS bus inside the fence  
 MMPA and MMPB are transmission customers

### 2 b).1 Agreement on losses

$$\begin{aligned} \text{MMPA}_{\text{energy}} &= \text{M1} + \text{SSLA}_{\text{TX}} - (\text{M2} + \text{SSZ} + \text{SSLAZ}) \\ \text{MMPA}_{\text{TT}} &= \text{M1} + \text{SSLA}_{\text{TX}} - (\text{M2} + \text{SSZ} + \text{SSLAZ}) \\ \text{MMPB}_{\text{energy}} &= \text{M2} + \text{SSZ} + \text{SSLAZ} \\ \text{MMPB}_{\text{TT}} &= \text{M2} + \text{SSZ} + \text{SSLAZ} \end{aligned}$$

### 2 b).2 No Agreement on losses (MMPB gets zero losses)

$$\begin{aligned} \text{SSZ} &= 0, \text{SSLAZ} = 0 \\ \text{MMPA}_{\text{energy}} &= \text{M1} + \text{SSLA}_{\text{TX}} - \text{M2} \\ \text{MMPA}_{\text{TT}} &= \text{M1} + \text{SSLA}_{\text{TX}} - \text{M2} \\ \text{MMPB}_{\text{energy}} &= \text{M2} \\ \text{MMPB}_{\text{TT}} &= \text{M2} \end{aligned}$$

Notes: 1. MMPA provides the loss calculation

**3. Feeder Meters - MMPA and MMPB Directly Connected to TS bus**

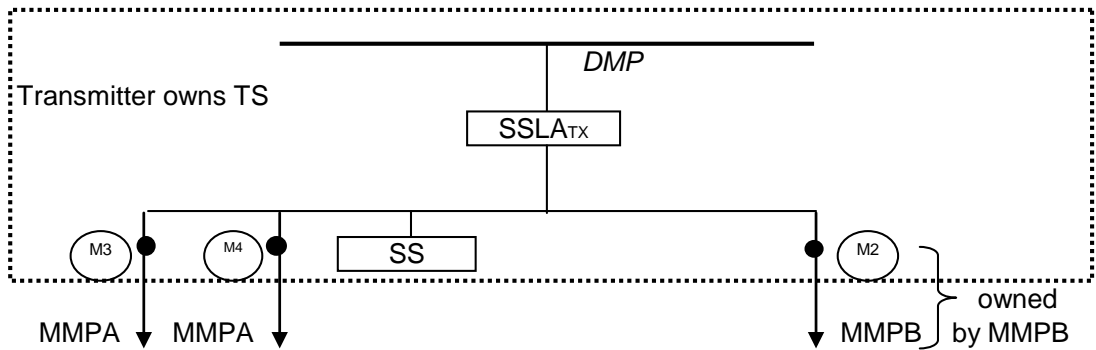

MMPA and MMPB are directly connected to the TS bus inside the fence  
 MMPA and MMPB are transmission customers

**3.1 Agreement on losses**

$$\begin{aligned} \text{MMPA}_{\text{energy}} &= \text{M3} + \text{M4} + \text{SSY} + \text{SSLAY} \\ \text{MMPA}_{\text{TT}} &= \text{M3} + \text{M4} + \text{SSY} + \text{SSLAY} \\ \text{MMPB}_{\text{energy}} &= \text{M2} + \text{SSZ} + \text{SSLAZ} \\ \text{MMPB}_{\text{TT}} &= \text{M2} + \text{SSZ} + \text{SSLAZ} \end{aligned}$$

**3.2 No Agreement on losses**

Based on breaker count of 3 breakers  
 same as above (with agreement) except losses calculated using  
 $Y = 2/3$   
 $Z = 1/3$

Notes: 1. MMPA provides the loss calculation

**4. Feeder Meters - MMPB embedded in MMPA Feeder**

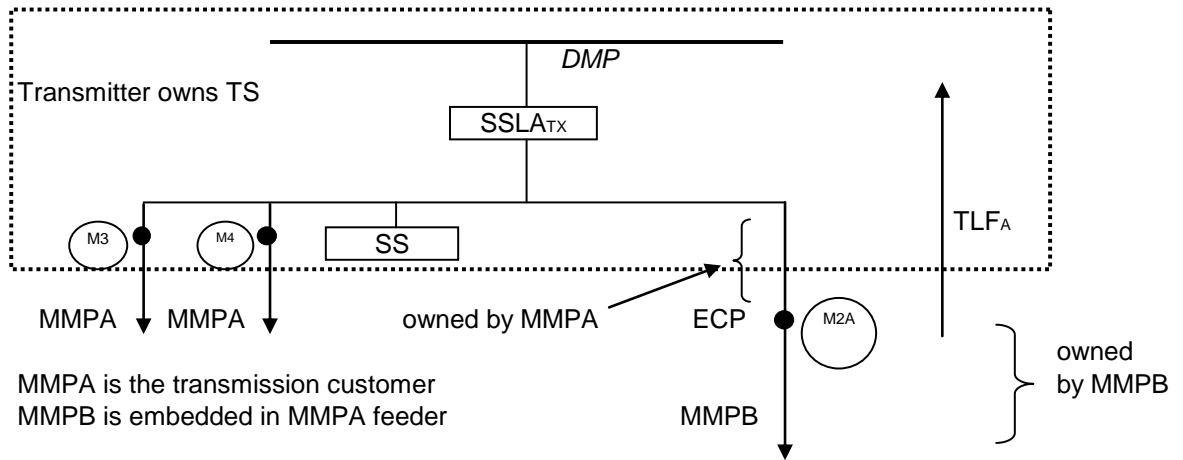

**4.1 No agreement on losses is required**

$$\begin{aligned}
 \text{MMPA}_{\text{energy}} &= \text{M3} + \text{M4} + \text{SSY} + \text{SSLAY} \\
 \text{MMPA}_{\text{TT}} &= \text{M3} + \text{M4} + \text{SSY} + \text{SSLAY} + \text{M2A} \cdot \text{TLF}_A \\
 \text{MMPB}_{\text{energy}} &= \text{M2A} \cdot \text{TLF}_A \quad \text{per OEB}
 \end{aligned}$$

**Notes:**

1. The TLF may have more than one value depending on the OEB approved rate - for example it may have a smaller value for an ECP close to the TS, and larger values further away from the TS e.g. HONI TLF
2. MMPA provides the loss calculation
3. Share Y = 2/3 based on breaker count used by MMPA

**5. MMPA and MMPB Directly Connected, MMPC Embedded in MMPB**

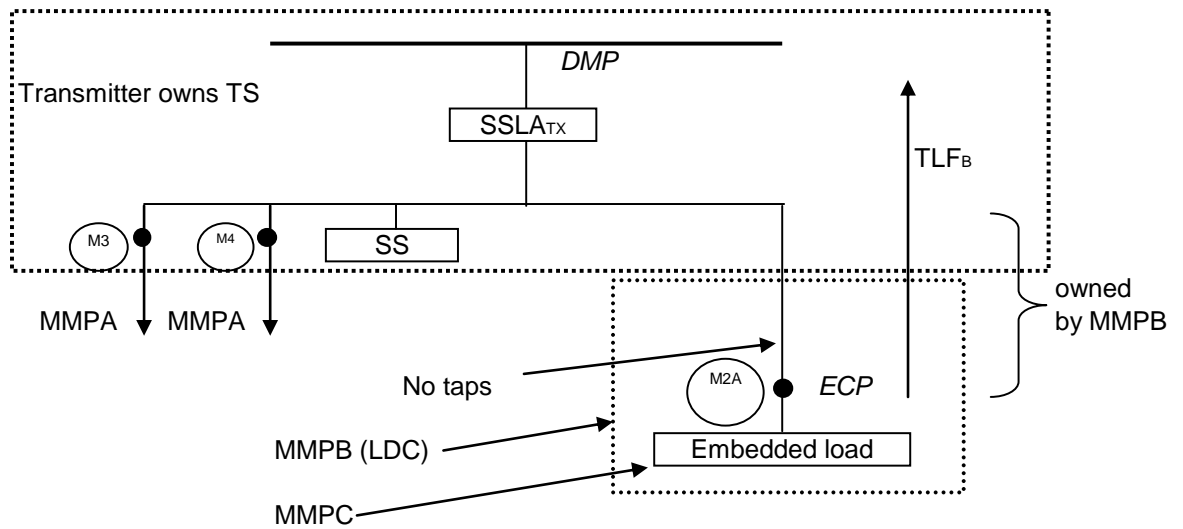

MMPA and MMPB are directly connected to the TS bus inside the fence  
 MMPA and MMPB are transmission customers

**5.1 No agreement on losses is required**

$MMPA_{energy} =$	$M3+M4+SSY+SSLAY$	
$MMPA_{TT} =$	$M3+M4+SSY+SSLAY$	
$MMPB_{TT} =$	$M2A.TLF_B$	
$MMPC_{energy} =$	$M2A.TLF_B$	per OEB

- Notes:
1. MMPA provides the loss calculation
  2. Loss share  $Y=2/3$  based on breaker count used by MMPA

**6 a). MMPA and MMPB Directly Connected, MMPC Embedded in MMPB - Feeder meters**

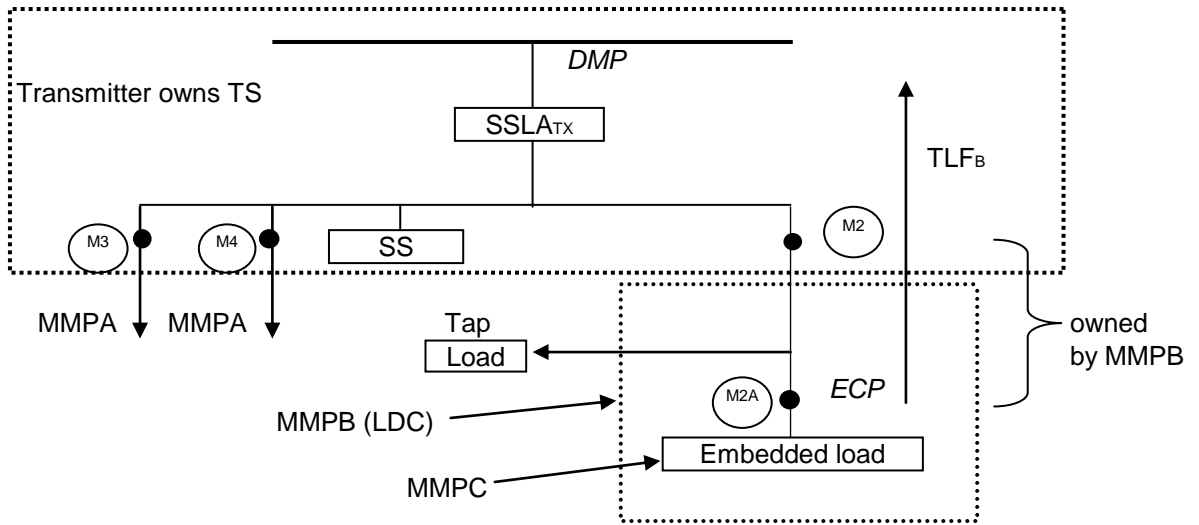

MMPA and MMPB are directly connected to the TS bus inside the fence  
 MMPA & the MMPB are both transmission customers  
 MMPA & the MMPB are the two parties that have to agree on losses

**6 a).1 Agreement on losses**

$MMPA_{energy} =$	$M3+M4+SSY+SSLAY$	
$MMPA_{TT} =$	$M3+M4+SSY+SSLAY$	
$MMPB_{energy} =$	$M2+SSZ+SSLAZ - M2A.TLFB$	
$MMPB_{TT} =$	$M2+SSZ+SSLAZ$	
$MMPC_{energy} =$	$M2A.TLFB$	per OEB

**6 a).2 No agreement on losses**

Same as above except A's loss factor is based on 2/3 and B's on 1/3

Notes: 1. MMPA provides the loss calculation

**6 b). MMPB and MMPC Embedded**

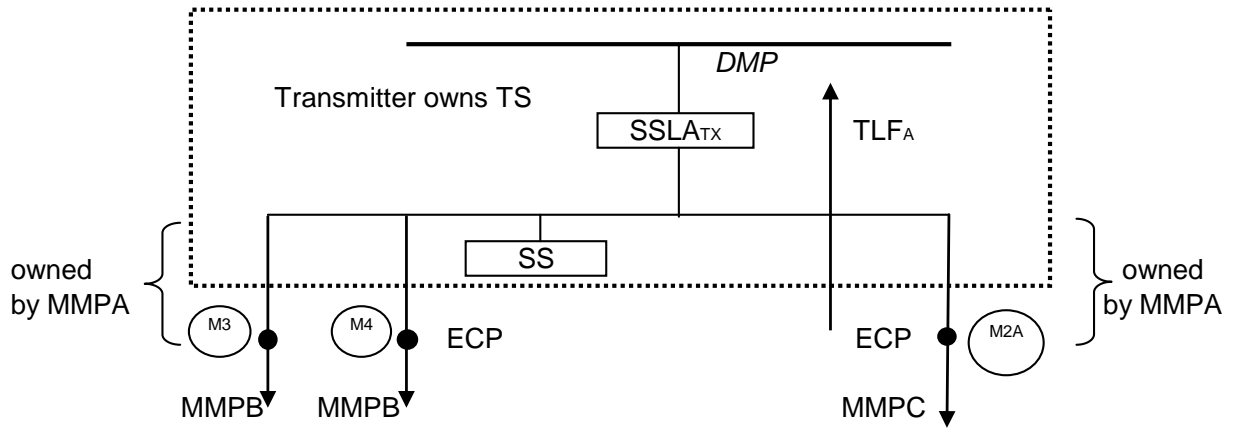

MMPB and MMPC have moved outside the fence  
 MMPB and MMPC are both embedded in MMPA feeders  
 MMPA is the transmission customer

**6 b).1 No agreement on losses is required.**

$$\begin{aligned}
 \text{MMPA}_{\text{TT}} &= \text{M3.TLF}_A + \text{M4.TLF}_A + \text{M2A.TLF}_A \\
 \text{MMPB}_{\text{energy}} &= \text{M3.TLF}_A + \text{M4.TLF}_A && \text{per OEB} \\
 \text{MMPC}_{\text{energy}} &= \text{M2A.TLF}_A && \text{per OEB}
 \end{aligned}$$

- Notes: 1. No SSLA calculation required  
 2. No station service metering required

**7 a). Multiple Embedded Distributors with taps**

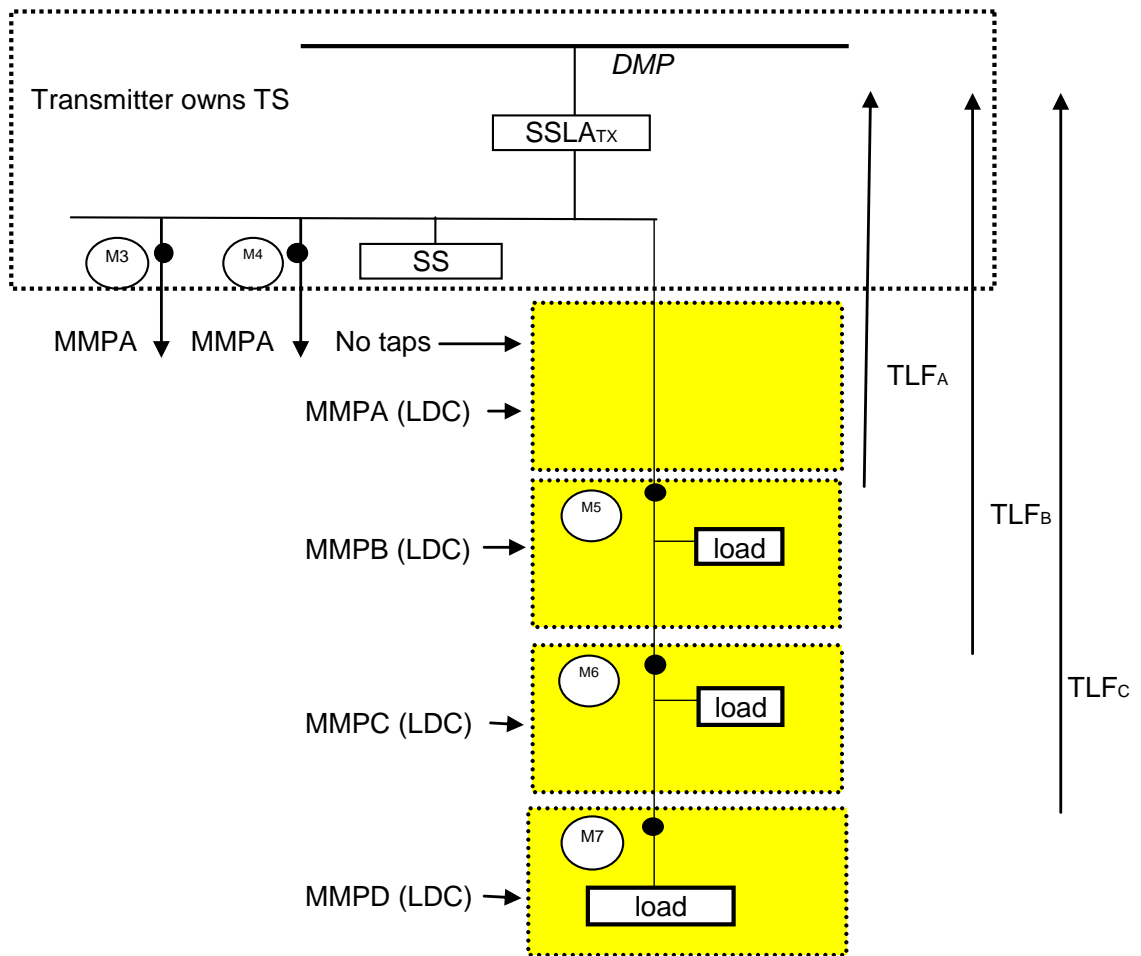

MMPA is directly connected to the bus inside the fence  
 MMPB, MMPC, and MMPD are embedded  
 MMPA is the transmission customer

**7 a)1. No agreement on losses is required**

$MMPA_{energy} =$	$M3+M4 + SSY+SSLAY$	
$MMPA_{TT} =$	$M3+M4 + M5.TLF_A+SSY+SSLAY$	
$MMPB_{energy} =$	$M5.TLF_A - M6.TLF_B$	per OEB
$MMPC_{energy} =$	$M6.TLF_B - M7.TLF_C$	per OEB
$MMPD_{energy} =$	$M7.TLF_C$	per OEB

Notes: 1. MMPA provides the loss calculation

**7 b). Embedded Distributors in Parallel**

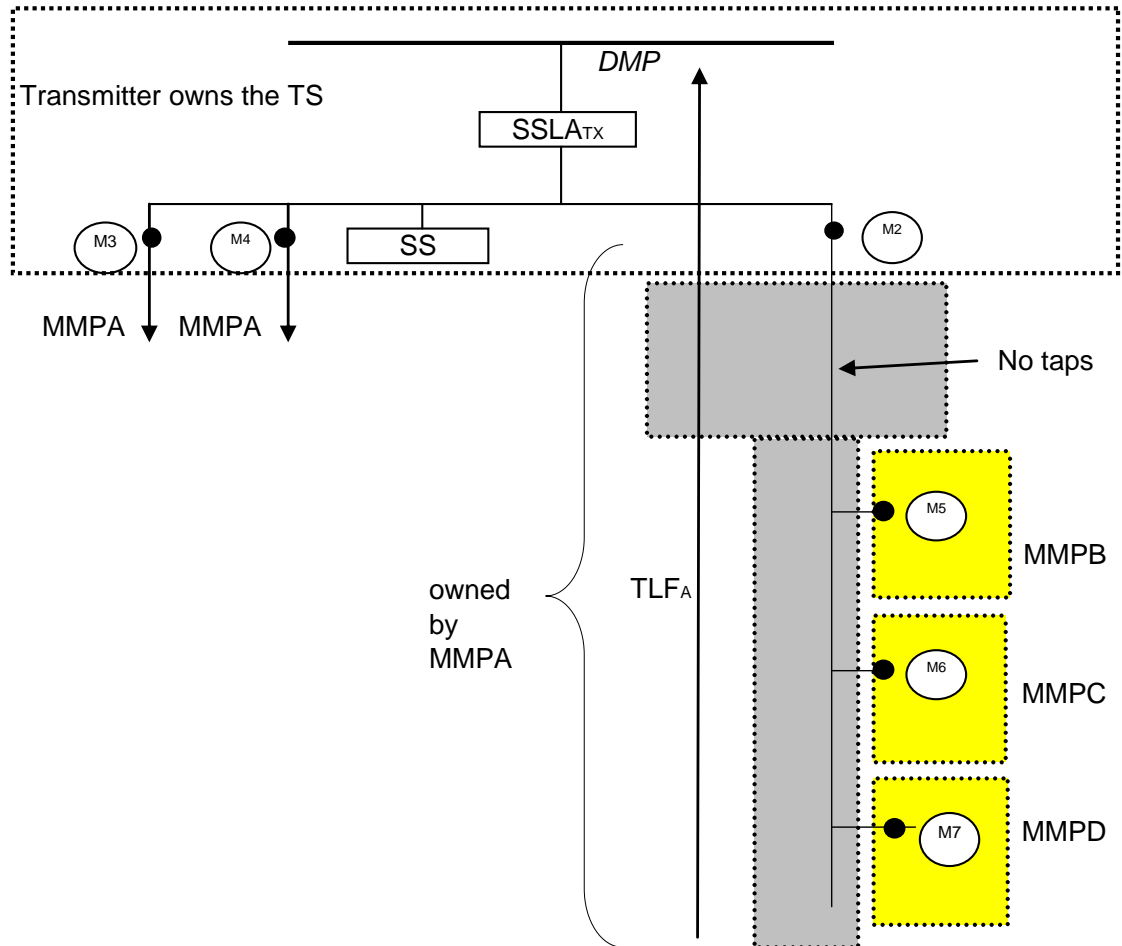

MMPA is directly connected  
 MMPA is the transmission customer  
 MMPB, MMPC and MMPD are embedded.

**7 b)1. No agreement on losses is required**

$$\begin{aligned}
 \text{MMPA}_{\text{energy}} &= \text{M3} + \text{M4} + \text{M2} + \text{SS} + \text{SSLA}_{\text{TX}} - \text{M5} \cdot \text{TLF}_A - \text{M6} \cdot \text{TLF}_A - \text{M7} \cdot \text{TLF}_A \\
 \text{MMPA}_{\text{TT}} &= \text{M3} + \text{M4} + \text{M2} + \text{SS} + \text{SSLA}_{\text{TX}} \\
 \text{MMPB}_{\text{energy}} &= \text{M5} \cdot \text{TLF}_A && \text{per OEB} \\
 \text{MMPC}_{\text{energy}} &= \text{M6} \cdot \text{TLF}_A && \text{per OEB} \\
 \text{MMPD}_{\text{energy}} &= \text{M7} \cdot \text{TLF}_A && \text{per OEB}
 \end{aligned}$$

Notes: 1. MMPA provides the loss calculation

**7 c). Embedded Distributors in Parallel (Meters Located between LDC Taps)**

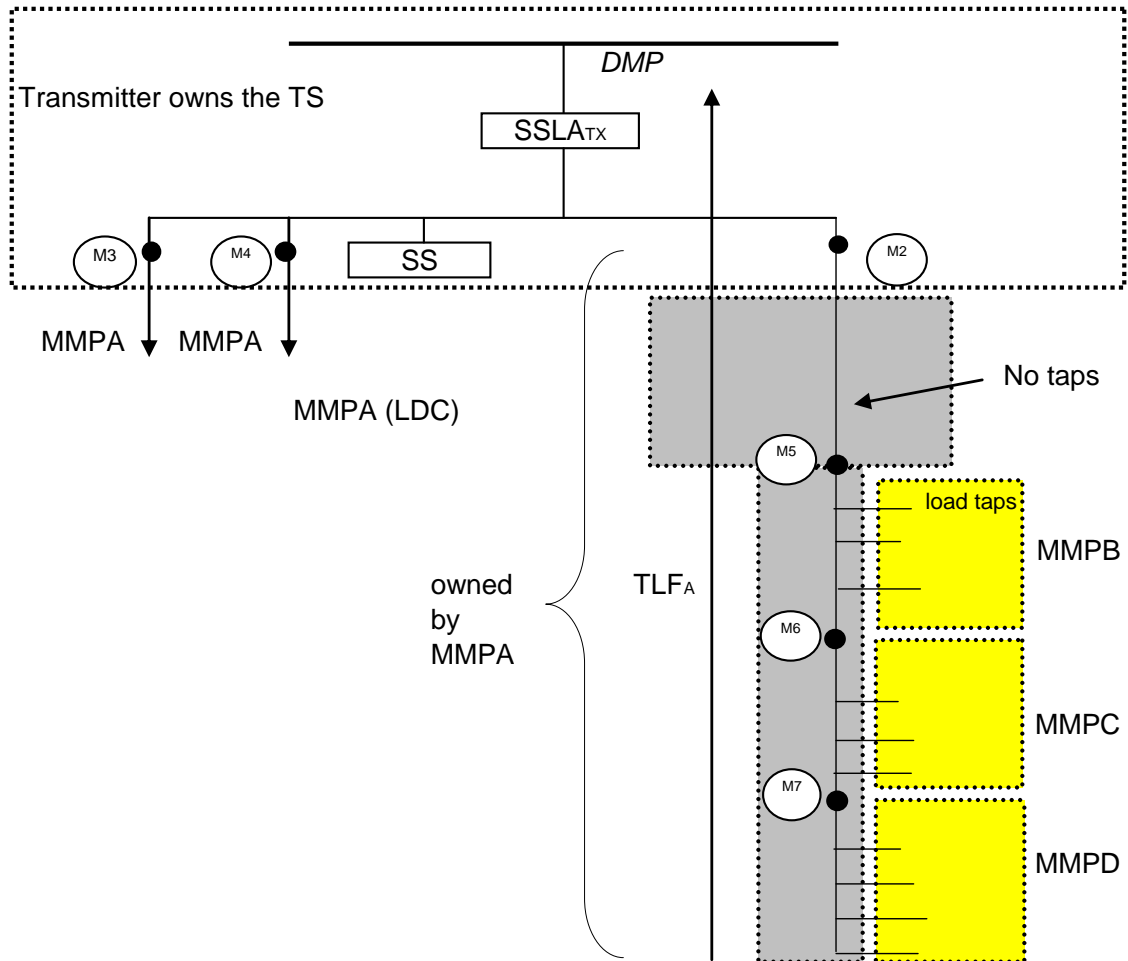

MMPA is directly connected  
 MMPA is the transmission customer  
 MMPB, MMPC and MMPD are embedded.

**7 c)1. No agreement on losses is required**

$MMPA_{energy} =$	$M3+M4+M2+SS+SSLA_{TX} - M5.TLF_A$	
$MMPA_{TT} =$	$M3+M4+M2+SS+SSLA_{TX}$	
$MMPB_{energy} =$	$M5.TLF_A - M6.TLF_A$	per OEB
$MMPC_{energy} =$	$M6.TLF_A - M7.TLF_A$	per OEB
$MMPD_{energy} =$	$M7.TLF_A$	per OEB

Notes: 1. MMPA provides the loss calculation

**8 a). Embedded Generator in an Embedded Distributor - Feeder Meters**

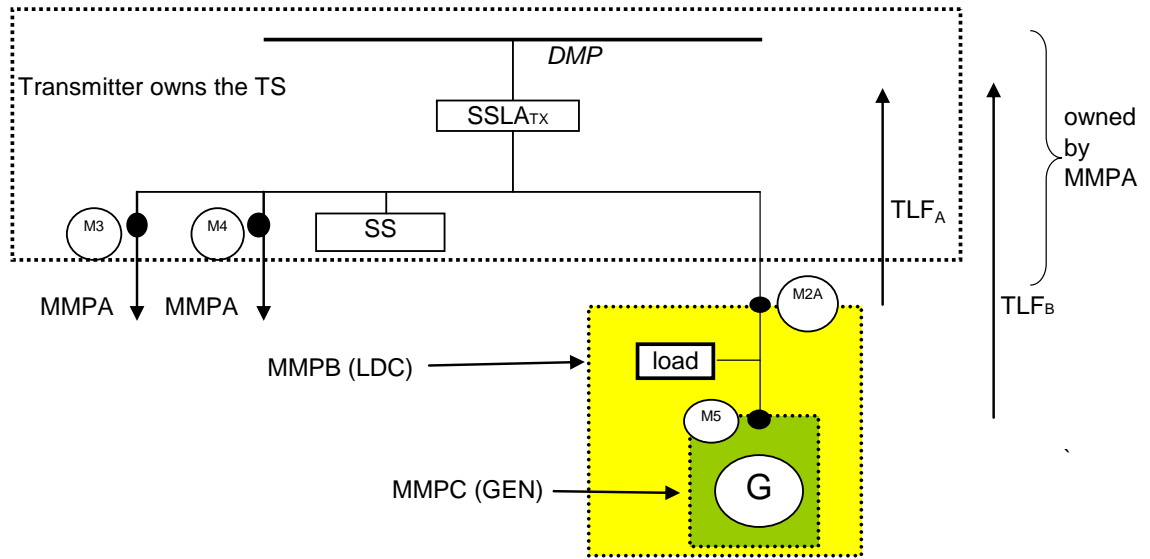

MMPA is directly connected  
 MMPA is the transmission customer  
 MMPB and MMPC are embedded

**8 a)1. No agreement on losses is required.**

MMPA <sub>energy</sub> =	M3+M4+SSY+SSLAY	
MMPA <sub>TT</sub> =	Check the appropriate transmission rate schedule for details	
MMPB <sub>energy</sub> =	M2A.TLF <sub>A</sub> - (M5C12.TLF <sub>B</sub> + M5C34.LF)	see note 2, 3 & 6.
MMPC <sub>energy</sub> =	M5 <sub>12</sub> .TLF <sub>B</sub> (delivered channels 1 & 2)	= M5C12.TLF <sub>B</sub> per OEB
	M5 <sub>34</sub> .LF (received channels 3 & 4)	= M5C34.LF see note 2 & 3.
	M5C12.TLF <sub>B</sub> + M5C34.LF	

- Note: 1. The embedded generator is an energy market participant  
 2. A default loss factor (LF) value of 1.0 will be used. Values other than 1.0 will be used if specified and agreed to by all parties.  
 3. M5C12 and M5C34 are direction dependent (ch 1 & 2 delivered, ch 3 & 4 received)  
 4. MMPA provides the loss calculations  
 5. MMPA responsible for station service metering  
 6. If the Generator output is higher than MMPB load, MMPA should install feeder metering or agree with MMPB the loss factor (LF1) to be applied to M2AC34 (Refer to example 8.b.2.)  
 The IESO will not accept loss factors that negatively impact the Market.

Example of transmission tariff settlement:  
 Using Ontario Transmission Rate Schedules and assuming  
 a non-renewable generator > 1 MW or a renewable generator > 2 MW  
 MMPA<sub>TT</sub> network = M3+M4+SSY+SSLAY + M2A.TLF<sub>A</sub>  
 MMPA<sub>TT</sub> connection = M3+M4+SSY+SSLAY + M2A.TLF<sub>A</sub> + M5C34.LF

**8 b). Embedded Generator in an Embedded Distributor - Bus Meter**

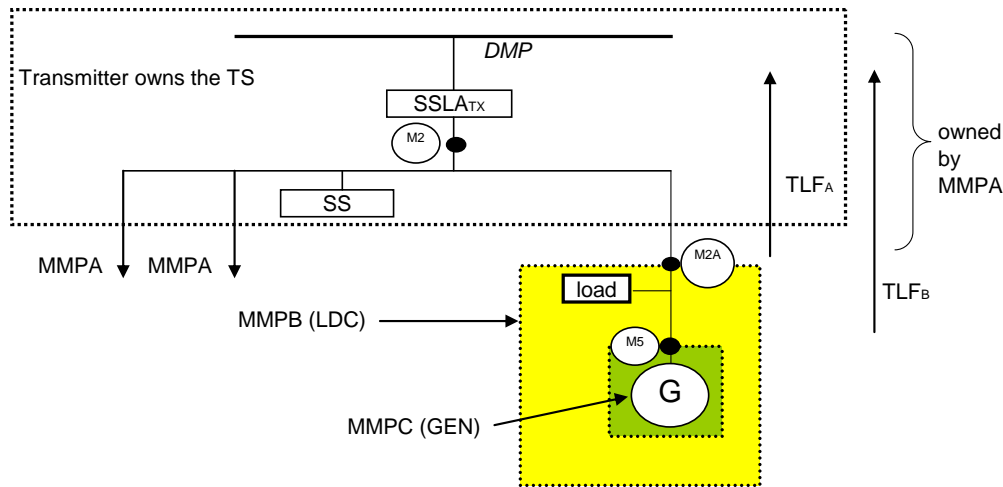

MMPA is directly connected  
MMPA is the transmission customer  
MMPB and MMPC are embedded

**8 b)1. No agreement between MMPA and MMPB is required if:**

During normal operating conditions the load is greater than the generator output.  
M2A registers non-zero values on Ch# 1 and zero values on Ch# 3.

MMPA <sub>energy</sub> =	M2+SSLA - M2A.TLFA	
MMPA <sub>TT</sub> =	Check the appropriate transmission rate schedule for details	
MMPB <sub>energy</sub> =	M2A.TLFA - (M5C12.TLFB + M5C34.LF)	see note 4.
MMPC <sub>energy</sub> =	M5 <sub>12</sub> .TLFB (delivered channels 1 & 2)	= M5C12.TLFB per OEB
	M5 <sub>34</sub> . LF (for received channels 3 & 4)	= M5C34.LF see note 2.
	= M5C12.TLFB + M5C34.LF	

**8 b)2. An agreement between MMPA and MMPB is required if:**

During normal operating conditions the generator output is greater than the load.  
M2A registers zero values on Ch# 1 and non-zero values on Ch# 3.

MMPA <sub>energy</sub> =	M2+SSLA - (M2AC12.TLFA + M2AC34.LF1)	see note 3.
MMPA <sub>TT</sub> =	Check the appropriate transmission rate schedule for details	
MMPB <sub>energy</sub> =	M2A <sub>12</sub> .TLFA (delivered channels 1 & 2)	= M2AC12.TLFA
	M2A <sub>34</sub> . LF1 (for received channels 3 & 4)	= M2AC34.LF1 see note 3.
	= (M2AC12.TLFA + M2AC34.LF1) - (M5C12.TLFB + M5C34.LF)	see note 4.
MMPC <sub>energy</sub> =	M5 <sub>12</sub> .TLFB (delivered channels 1 & 2)	= M5C12.TLFB per OEB
	M5 <sub>34</sub> . LF (received channels 3 & 4)	= M5C34.LF see note 2 & 4.
	= M5C12.TLFB + M5C34.LF	

- Note: 1. The embedded generator is an energy market participant  
2. A default loss factor (LF) value of 1.0 will be used. Values other than 1.0 will be used if specified and agreed to by all parties.  
3. Based on agreement, loss factor (LF1) is applied. If an agreement does not exist, LF1=TLFA (Refer to example 8.a.1).  
4. M5C12 and M5C34 are direction dependent (ch 1 & 2 delivered, ch 3 & 4 received)  
5. MMPA provides the loss calculations  
6. MMPA responsible for station service metering

Example of transmission tariff settlement:  
Using Ontario Transmission Rate Schedules and assuming  
a non-renewable generator > 1 MW or a renewable generator > 2 MW  
MMPA<sub>TT</sub> network = M2+SSLA  
MMPA<sub>TT</sub> connection = M2+SSLA+ M5C34.LF

– End of Section –

# Appendix E: Example of a Site Registration Report (SRR)

Site Registration Report for 102224 Generated by MV-STAR on Mon Jan 13 16:51:50 EST 2003

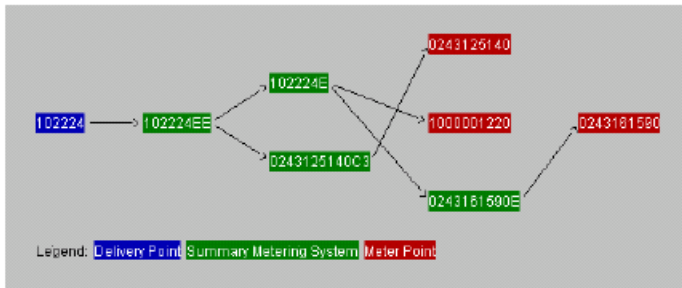

Delivery point 102224 is associated with 102224EE from Tue Jan 01 00:00:00 EST 2002 with no end date

### Channel summary for 102224EE

- 1) 5 minute, Summary channel, UOM 1, Power Flow I, Voltage Code None
- 2) 5 minute, Summary channel, UOM 3, Power Flow I, Voltage Code None
- 3) 5 minute, Summary channel, UOM 1, Power Flow E, Voltage Code None
- 4) 5 minute, Summary channel, UOM 3, Power Flow E, Voltage Code None

### Detailed channel information for 102224EE

```

102224EE: Channel 1, 5 minute, Summary channel, UOM 1, Power Flow I, Voltage Code None
+ 100.0% of 102224E: Channel 1: Contribution DateRange[2002-Jan-01 00:00,null]
  5 minute, Summary channel, UOM 1, Power Flow I, Voltage Code None
+ 100.0% of 1000001220: Channel 1: Contribution DateRange[2002-Jan-01 00:00,null]
  5 minute, M channel, UOM 1, Power Flow I, Voltage Code 575
- 100.0% of 0243161590E: Channel 1: Contribution DateRange[2002-Mar-01 00:00,2003-Jan-06 00:00]
  5 minute, Summary channel, UOM 1, Power Flow I, Voltage Code None
+ 100.0% of 0243161590: Channel 1: Contribution DateRange[2002-Mar-01 00:00,null]
  15 minute, S channel, UOM 1, Power Flow I, Voltage Code 404
  Assumed Voltage:120.0 Assumed PF:0.950000 CT:200.0 PT:1000.0 ServiceType:W

- 100.0% of 0243125140C3: Channel 1: Contribution DateRange[2002-Jul-01 00:00,null]
  15 minute, Summary channel, UOM 1, Power Flow I, Voltage Code 018
+ 100.0% of 0243125140: Channel 3: Contribution DateRange[2002-Jul-01 00:00,null]
  15 minute, S channel, UOM 1, Power Flow I, Voltage Code None
102224EE: Channel 2, 5 minute, Summary channel, UOM 3, Power Flow I, Voltage Code None
+ 100.0% of 102224E: Channel 2: Contribution DateRange[2002-Jan-01 00:00,null]
  5 minute, Summary channel, UOM 3, Power Flow I, Voltage Code None

```

Site Registration Report for 102224 Generated by MV-STAR on Mon Jan 13 16:51:50 EST 2003

```

+ 100.0% of 1000001220: Channel 2: Contribution DateRange[2002-Jan-01 00:00,null]
  5 minute, M channel, UCM 3, Power Flow I, Voltage Code 575
102224EE: Channel 3, 5 minute, Summary channel, UCM 1, Power Flow E, Voltage Code None
+ 100.0% of 102224E: Channel 3: Contribution DateRange[2002-Jan-01 00:00,null]
  5 minute, Summary channel, UCM 1, Power Flow E, Voltage Code None
+ 100.0% of 1000001220: Channel 3: Contribution DateRange[2002-Jan-01 00:00,null]
  5 minute, M channel, UCM 1, Power Flow E, Voltage Code 575
102224EE: Channel 4, 5 minute, Summary channel, UCM 3, Power Flow E, Voltage Code None
+ 100.0% of 102224E: Channel 4: Contribution DateRange[2002-Jan-01 00:00,null]
  5 minute, Summary channel, UCM 3, Power Flow E, Voltage Code None
+ 100.0% of 1000001220: Channel 4: Contribution DateRange[2002-Jan-01 00:00,null]
  5 minute, M channel, UCM 3, Power Flow E, Voltage Code 575
    
```

Voltage code information

```

Voltage code 404
  Precedence 1, E1099 (Equation loss), 2000/10/01 00:00- , 0*(I4H) + 5.3373*(I2H) + 0*(V4H) +
  0.001099*(V2H) + 0
Voltage code 018
  Precedence 1, D28 (Fixed loss), 2000/10/01 00:00 - , Factor 3.4000000000000004%
Voltage code 575
  Precedence 1, E405 (Equation loss), 2000/10/01 00:00- , 0.0405*(KVA2H) + -0.2941*(KVAH) + 95.5
    
```

The Totalization Table as reflected in this Site Registration Report, for the specified Delivery Point, truly represents the configuration of that delivery point with respect to metering requirements as specified in the Market Rules and other relevant standards, procedures and policies of the IMO.

\_\_\_\_\_  
MSP Name and ID (print)

\_\_\_\_\_  
Transmitter Name (print)

\_\_\_\_\_  
Signature and Date

\_\_\_\_\_  
Signature and Date

## 1 Report Title

- The Site Registration Report is for *delivery point* 102224 that was generated by MV-STAR on Monday, January 13, 2003 at 16:51:50 Eastern Standard Time.

## 2 Meter Tree Picture

- Meter* 0243161590 contributes to summary meter 0243161590E. Both summary meter 0243161590E and *meter* 10000012220 contribute to summary meter 102224E.
- Meter* 0243125140 contributes to summary meter 0243125140C3.
- Both summary meters 102224E and summary meter 0243125140C3 contribute to THE summary meter 102224EE.
- THE summary meter 102224EE contributes to *Delivery Point* 102224.

3 The *delivery point* associated to THE summary meter from a start date to an end date.

- Delivery Point* 102224 has THE summary meter 102224EE contributing starting on Tuesday, January 1, 2002 at 00:00 hours Eastern Standard Time with no end date.

## 4 Channel Summary for THE summary meter.

- the makeup of The summary meter 102224EE is as follows:

Listing of channels	ch1	ch2	ch3	ch4
Interval length	5 mins	5 mins	5 mins	5 mins
Type of meter	Summary	Summary	Summary	Summary
Unit of Measurement	KWH	KVARH	KWH	KVARH
Direction of Power Flow	Import	Import	Export	Export
Voltage Code (None)	no losses	no losses	no losses	no losses

- Assumed Voltage, Assumed PF, CT ratio, PT ratio and ServiceType (D=Delta, or W=Wye) Since there is no Voltage Code the above is not printed.

## 5 Detailed Channel Information for THE Summary Meter

- THE summary meter 102224EE of channel 1 with parameters; 5 minute intervals, is a summary meter, KWH, direction of flow Import/delivered/withdrawal, no losses applied receives metering data contributions from:
  - meter* 102224E of channel 1 adds all of the *metering data* that started on 2002-Jan-01 at 00:00 hours and has 'null' for end date). The *meter* consists of the following parameters; 5 minute intervals, is a summary meter, KWH, direction of flow Import/delivered/withdrawal, no losses applied.
  - meter* 1000001220 of channel 1 adds all of the *metering data* that started on 2002-Jan-01 at 00:00 hours and has 'null' for the end date. The *meter* consists of the following parameters; 5 minute intervals, is a Main meter, KWH, direction of flow Import/delivered/withdrawal, with voltage Code 575.
  - meter* 0243161590E of channel 1 subtracts all of the *metering data* that started on 2002-Mar-01 at 00:00 hours and has end date of 2003-Jan-06 at 00:00 hours. The *meter* consists of the following parameters; 5 minute intervals, is a Summary meter, KWH, direction of

flow Import/delivered/withdrawal, with no losses applied. (Note: This *meter* stops contributing *metering data* starting 2003-Jan-06 at 00:00 hours).

- *meter* 0243161590 of channel 1 adds all of the *metering data* that started on 2002-Mar-01 at 00:00 hours and ‘null’ for the end date. The *meter* consists of the following parameters; 15 minute intervals, is a Standalone meter, KWH, direction of flow Import/delivered/withdrawal, with voltage Code 404 and the assumed Voltage parameters: 120V, 0.95, 200, 1000, Wye. (Note: This *meter’s* contribution of *metering data* starting 2003-Jan-06 at 00:00 hours is no longer effective because of the summary meter 0243161590E above has an end date of 2003-Jan-06 at 00:00 hours).
- *meter* 0243125140C3 of channel 1 subtracts all of the *metering data* that started on 2002-July-01 at 00:00 hours and ‘null’ for the end date. The *meter* consists of the following parameters; 15 minute intervals, is a summary meter, KWH, direction of flow Import/delivered/withdrawal, with voltage Code 018.
- *meter* 0243125140 of channel 3 adds all of the *metering data* that started on 2002-July-01 at 00:00 hours and ‘null’ for the end date. The *meter* consists of the following parameters; 15 minute intervals, is a Standalone meter, KWH, direction of flow Import/delivered/withdrawal, with no losses applied.
- THE summary meter 102224EE of channel 2 with parameters; 5 minute intervals, is a summary meter, KVARH, direction of flow Import/delivered/withdrawal, no losses applied receives *metering data* from:
 

Same logic as described for channel 1
- THE summary meter 102224EE of channel 3 with parameters; 5 minute intervals, is a summary meter, KWH, direction of flow Export/received/injection, no losses applied receives *metering data* from:
 

Same logic as described for channel 1
- THE summary meter 102224EE of channel 4 with parameters; 5 minute intervals, is a summary meter, KVARH, direction of flow Export/received/injection, no losses applied receives *metering data* from:
 

Same logic as described for channel 1

## 6 Voltage Code Information

Voltage Code 404 uses loss factor E1099 that is a method 1 equation loss with a start date of 2000/10/01 at 00:00 hours with no end date. The coefficients are 5.3373 for I2H and 0.001099 for V2H.

Voltage Code 018 uses loss factor D28 that is a TLF (fixed loss) with a start date of 2000/10/01 at 00:00 hours with no end date. The factor is 3.4% which reflects the TLF of 0.034 from the “Totalization Table Form”.

Voltage Code 575 uses loss factor E405 that is a method 2 equation loss with a start date of 2000/10/01 at 00:00 hours with no end date. The coefficients are 0.0405 for KVA2H, -0.2941 for KVAH and 95.5 for the constant.

## 7 Signature

Self-explanatory

– End of Section –

# Appendix F: Example of a Compliance Aggregation Model

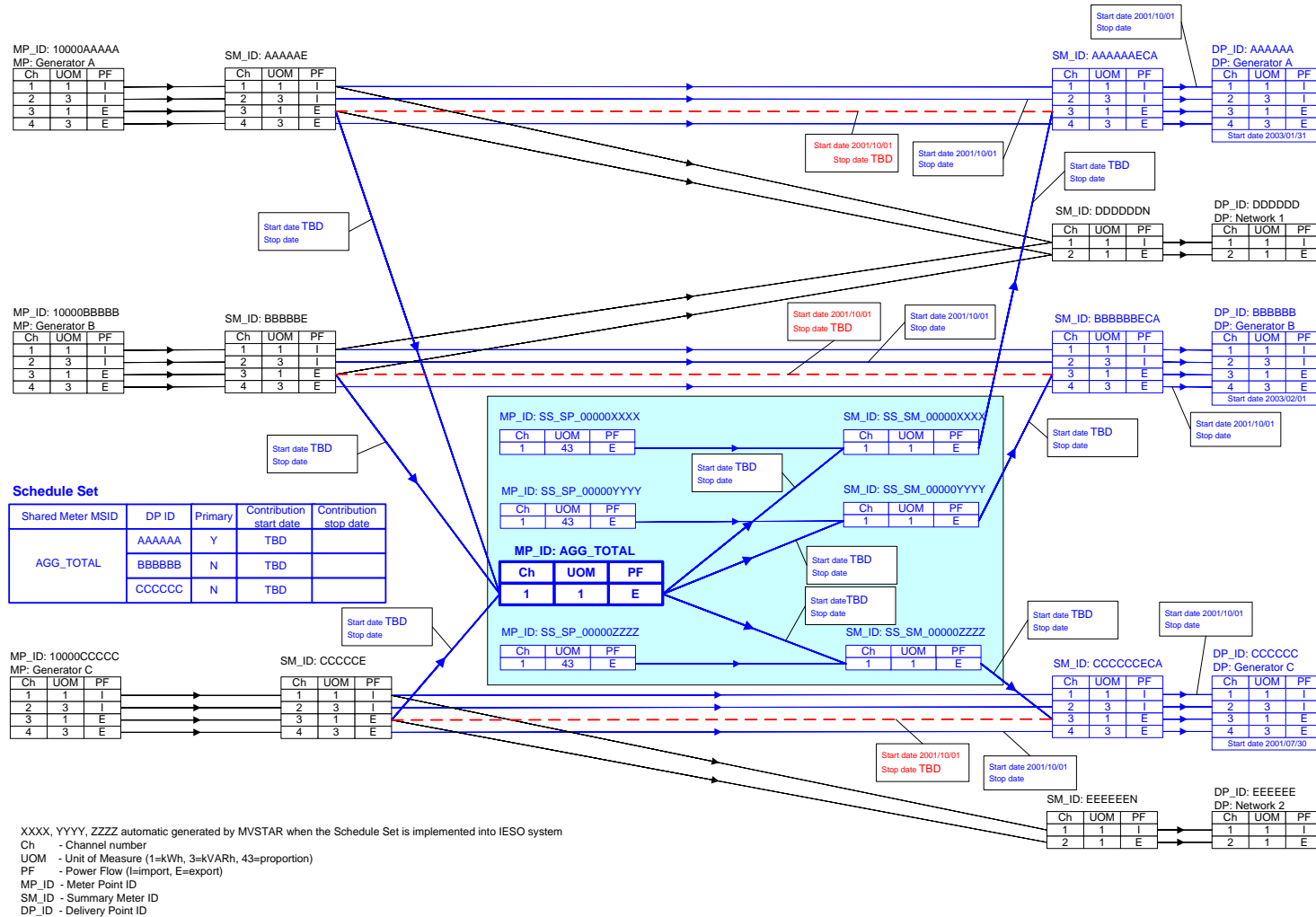

- End of Section -



# Appendix G: Example of a Meter Disaggregation Model

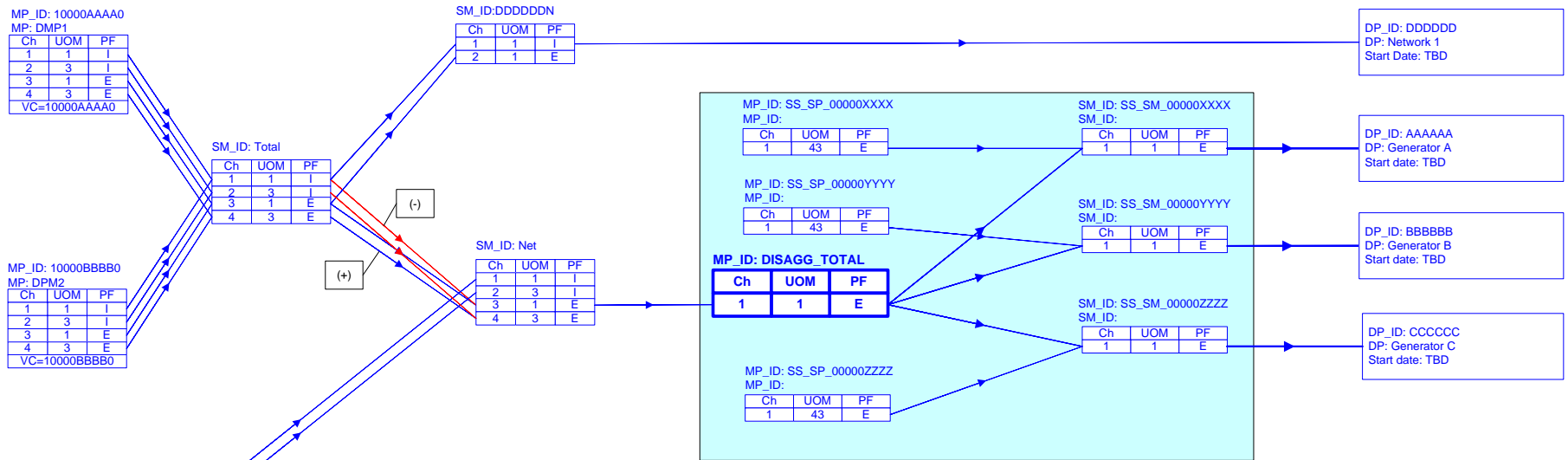

XXXX, YYYY, ZZZZ automatic generated by MVSTAR when the Schedule Set is implemented into IESO system  
 Ch - Channel number  
 UOM - Unit of Measure (1=kWh, 3=kVARh, 43=proportion)  
 PF - Power Flow (I=import, E=export)  
 MP\_ID - Meter Point ID  
 SM\_ID - Summary Meter ID  
 DP\_ID - Delivery Point ID  
 VC - Voltage Code

Schedule Set

Shared Meter MSID	DP ID	Primary	Contribution start date	Contribution stop date
DISAGG_TOTAL	AAAAAA	Y	TBD	
	BBBBBB	N	TBD	
	CCCCCC	N	TBD	

- End of Section -



## References

---

<b>Document ID</b>	<b>Document Title</b>
MDP_RUL_0002	Market Rules for the Ontario Electricity Market
MDP_PRO_0016	Market Manual 1: Market Entry, Maintenance and Exit, Part 1.2: Facility Registration, Maintenance and De-Registration
MDP_PRO_0017	Market Manual 2: Market Administration, Part 2.1:Dispute Resolution
MDP_MAN_0003	Market Manual 3: Metering, Part 3.0: Metering Overview
MDP_PRO_0013	Market Manual 3: Metering, Part 3.2: Meter Point Registration and Maintenance
MDP_PRO_0010	Market Manual 3: Metering, Part 3.4: Measurement Error Correction
MDP_PRO_0011	Market Manual 3: Metering, Part 3.5: Site-Specific Loss Adjustment
MDP_PRO_0012	Market Manual 3: Metering, Part 3.6: Conceptual Drawing Review
IMP_PRO_0057	Market Manual 3: Metering, Part 3.8: Creating and Maintaining Delivery Point Relationships
IMP_PRO_0034	Market Manual 4: Market Operations, Part 4.3: Real-Time Scheduling of the Physical Markets

– End of Document –