

PROCEDURE



Power to Ontario.
On Demand.

Market Manual 3: Metering
Part 3.4: Measurement
Error Correction

Issue 9.0

This document provides guidance to *metering service providers* on how to calculate and submit Measurement Error Correction (MEC) to the *IESO*.

Disclaimer

The posting of documents on this Web site is done for the convenience of *market participants* and other interested visitors to the *IESO* Web site. Please be advised that, while the *IESO* attempts to have all posted documents conform to the original, changes can result from the original, including changes resulting from the programs used to format the documents for posting on the Web site as well as from the programs used by the viewer to download and read the documents. The *IESO* makes no representation or warranty, express or implied, that the documents on this Web site are exact reproductions of the original documents listed. In addition, the documents and information posted on this Web site are subject to change. The *IESO* may revise, withdraw or make final these materials at any time at its sole discretion without further notice. It is solely your responsibility to ensure that you are using up-to-date documents and information.

This *market manual* may contain a summary of a particular *market rule*. Where provided, the summary has been used because of the length of the *market rule* itself. The reader should be aware, however, that where a *market rule* is applicable, the obligation that needs to be met is as stated in the *market rules*. To the extent of any discrepancy or inconsistency between the provisions of a particular *market rule* and the summary, the provision of the *market rule* shall govern.

Document ID	MDP_PRO_0010
Document Name	Part 3.4: Measurement Error Correction
Issue	Issue 9.0
Reason for Issue	Issue Released for Baseline 16.0
Effective Date	September 13, 2006

Document Change History

Issue	Reason for Issue	Date
1.0	Approved by the IMO Board	April 7, 2000
2.0	Board approved version released for Baseline 3.0	June 2, 2000
3.0	Board approved version released for Baseline 5.0	January 8, 2001
4.0	Issue Released for Baseline 7.0	January 16, 2002
5.0	Issue Released for Baseline 10.0	September 10, 2003
6.0	Issue Released for Baseline 10.1	December 10, 2003
7.0	Issue Released for Baseline 12.1	December 8, 2004
8.0	Issue Released for Baseline 14.1	December 7, 2005
9.0	Issue Released for Baseline 16.0	September 13, 2006

Related Documents

Document ID	Document Title
IMP_PRO_0014	Internal Manual 3: Settlements, Part 3.4: Meter Point Registration and Maintenance
IMP_PRO_0047	Market Manual 3: Metering Part 3.7: Totalization Table Registration
MDP_PRO_0013	Market Manual 3: Metering, Part 3.2: Meter Point Registration and Maintenance

Table of Contents

Table of Contents	i
List of Figures	ii
Table of Changes	iii
Market Manuals	1
Market Procedures	1
1. Introduction	3
1.1 Purpose.....	3
1.2 Scope.....	3
1.3 Overview	4
1.4 Roles and Responsibilities.....	4
1.5 Contact Information	5
2. Procedural Work Flow	7
3. Procedural Steps	9
Appendix A: Forms	A-1
Appendix B: Calculation of Error Correction Factors	B-1
References	1

List of Figures

Figure 2–1: Procedural Work Flow for Measurement Error Correction (MEC)	8
Figure B-1: Instrument Transformer Data.....	B–4
Figure B-2: Calculation of MEC Factors for Instrument Transformers and VT Lead Wire .	B–5
Figure B-3: Unit Resistance for Various Wire Sizes.....	B–6
Figure B-4: Connection Diagram for VT's Using Six-Conductor Cabling.....	B–8
Figure B-5: Calculation of MEC Factors for VT Lead Wires Feeding a “High-Impedance” Metering Installation.....	B–9
Figure B-6: Calculation of MEC Factors for Six-Conductor VT Cabling Where AC Supply for the Meter is Provided by the Measuring VT	B–10
Figure B-7: Calculation of Figure B-6 cont'd.....	B–11
Figure B-8: Metering Installation Using Four-Conductor VT Cabling	B–12
Figure B-9: Calculation of MEC Factors for Four-Conductor VT Cabling Where AC Supply for the Meter is Provided by the Measuring VT	B–13
Figure B-10: Calculation of Figure B-9 cont'd.....	B–14
Figure B-11: Calculation of MEC Factors for a Delta-Metered Transmission Line	B–17
Figure B-12: Connection Diagram Illustrating the Physical Separation of Instrument Transformers	B–19
Figure B-13: Meaning of Symbols Used in the Calculations in Figures 14 and 15	B–19
Figure B-14: Calculation of MEC Factors Required by the Physical Separation of CTs and VTs.....	B–20
Figure B-15: Calculation of Figure 14 cont'd	B–21
Figure B-16: Calculation of MEC Factors for a Two-and-a-Half Element Metering Installation Measuring a Wye-Connected Power Transformer.....	B–22
Figure B-17: Graph Illustrating the Distribution of Errors Calculated in Figure B-16	B–23
Figure B-18: Exploded Area for the Graph Shown in Figure 17.....	B–24
Figure B-19: Residual Voltage Versus Residual Current Graph	B–25
Figure B-20: Calculation of MEC Factors for a Two-and-a-Half Element Metering Installation Measuring a Wye-Connected Power Transformer.....	B–26

Table of Changes

Reference	Description of Change
Appendix B: Section B.4.3	Updated this section in accordance with “Wholesale Revenue Metering Standard – Hardware”, Section 4.3.3.
References	Included: <ul style="list-style-type: none"><li data-bbox="548 569 1235 600">• “Wholesale Revenue Metering Standard – Hardware”;<li data-bbox="548 615 1403 646">• “Handbook for Electricity Metering”, Edison Electric Institute, 1992

Market Manuals

The *market manuals* consolidate external procedures and associated forms, standards, and policies that define certain elements relating to the operation of the *IESO-administered markets*. External procedures are guides for the use of *market participants* that provide a more detailed description of the requirements for various activities than is specified in the *market rules*. Standards and policies provide a supporting framework for the external procedures. Where there is a discrepancy between the requirements in a document within a *market manual* and the *market rules*, the *market rules* shall prevail.

Market Procedures

The “Metering Manual” is volume 3 of the *market manuals*, where this document forms “Part 3.4: Measurement Error Correction”.

A list of the other component parts of the “Metering Manual” is provided in “Part 3.0: Metering Overview” in section 2, About this Manual.

Structure of Market Procedures

Each market procedure is composed of the following sections:

1. **“Introduction”**, which contains general information about the procedure, including an overview, a description of the purpose and scope of the procedure, and information about roles and responsibilities of the parties involved in the procedure.
2. **“Procedural Work Flow”**, which contains a graphical representation of the steps and flow of information within the procedure.
3. **“Procedural Steps”**, which contains a table that describes each step and provides other details related to each step.
4. **“Appendices”**, which may include such items as forms, standards, policies, and agreements.

Conventions

The *market manual* standard conventions are as defined in the “Market Manual Overview” document.

– End of Section –

1. Introduction

1.1 Purpose

This procedure applies to *metering service providers* and all *metering installations* that are registered or intended to be registered in the context of the *IESO-administered markets*.

1.2 Scope

This procedure is intended to provide *market participants* with a summary of the steps and interfaces between *market participants*, the *IESO*, and other parties for performing a measurement error correction. The procedural steps and work flows described in this document serve as a roadmap for *market participants* and the *IESO*, and should be used in conjunction with the *market rules*. The overview information in Section 1.3, below, is provided for convenience of reference only and highlights the main actions that comprise the procedure as described in greater detail in later sections of this document.

Measurement Error Correction (MEC) is required for:

- Voltage transformer cabling where the final correction factor (as defined by “Handbook for Electricity Metering” - Reference, Edison Electric Institute, 1992) for active and reactive power falls outside the range of 0.9998 to 1.0002;
- *Metering installations* that are not compliant with Blondel's Theorem where the resulting maximum error exceeds 0.2%;
- Physical separation of voltage transformers and current transformers used in *metering installations* pertaining to *facilities* where the resulting maximum error exceeds 0.02%; and

Other operational circumstances, including:

- Leakage current between the location of the voltage and the current transformers used in *metering installations* pertaining to a *generation facility* that introduces a maximum error that exceeds 0.02%;
- Primary cables of voltage transformers that introduces a maximum error that exceeds 0.02%;
- Current transformers normally operating at less than 10% of the rated primary current;
- Voltage transformer having two secondary windings that introduces a maximum error that exceeds 0.02%; and
- Power system switching that introduces a maximum error that exceeds 0.02% that:
 - causes the *meter* to be by-passed, either completely or partially; or
 - causes electrical separation of CT primaries in a CT summated *metering installation*.

Measurement Error Correction (MEC) is not required for:

- Voltage transformers (VTs) and current transformers (CTs) that do not meet the 0.3 Accuracy Class of IEEE Std C57.13 Standard Requirements for Instrument Transformers;¹

1.3 Overview

Metering data obtained from *metering installations* requires measurement error corrections (MEC) to address inaccuracies introduced by certain elements or conditions associated with a *metering installation*. At the time that a *meter point* associated with a *metering installation* is registered, *metering service providers* must submit (even if MEC equals one) MEC factors to the *IESO*, by using the Measurement Error Correction Register available on the *IESO's* Web site. (See also “Metering Manual 3: Metering Part 3.2: Meter Point Registration”.) *Metering service providers* must also ensure that the Measurement Error Correction Register that contains the required MEC factors is stamped and signed by a registered professional engineer. In addition, *metering service providers* must update the MEC Register whenever changes to the *metering installations* that are likely to alter the existing MEC factors are carried out, by following the relevant procedure described in “Market Manual 3: Metering Part 3.2: Meter Point Registration”.

1.4 Roles and Responsibilities

The responsibility for carrying out measurement error correction is divided between:

Metering service providers, which are responsible for:

- enlisting the services of a registered professional engineer to carry out the calculation of MEC factors;
- facilitating to the registered professional engineer access to actual, operational data relevant for the calculation of MEC factors;
- ensuring that the registered professional engineer stamps and signs the MEC Register;
- submitting final MEC factors to the *IESO* in support of an application to register a *metering installation*; and
- update the MEC Register whenever changes to the *metering installation* that are likely to alter the existing MEC factors are carried out

The *IESO*, which is responsible for:

- receiving the final MEC factors.

¹ Previously, the *IESO* was to have applied a MEC factor starting on 1st May 2006. This is no longer in effect – the *IESO* will not apply a MEC factor for ITs that are registered under the Alternative Metering Installation Standards. There is no time limitation.

1.5 Contact Information

If the *market participant* wishes to contact the *IESO*, the *market participant* can contact the *IESO* Customer Relations via email at customer.relations@ieso.ca or via telephone, mail or courier to the numbers and addresses given on the *IESO*'s Web site (www.ieso.ca - or click on 'Have a question?' to go to the 'Contacting the IESO' page). If the *IESO* Customer Relations is closed, telephone messages or emails may be left in relevant voice or electronic *IESO* mail boxes, which will be answered as soon as possible by Customer Relations staff.

Standard forms that participants must complete for this procedure are listed in Appendix A. These forms are "Inside the Market" available for downloading on the *IESO*'s public Web site. These signed forms as well as the accompanying supporting documentation must be transmitted to the *IESO* via mail or courier by using the appropriate address provided on the *IESO*'s public Web site or on the form. All correspondence relating to this procedure shall identify the subject: **Measurement Error Correction**.

– End of Section –

2. Procedural Work Flow

The following diagram represents the flow of work and information related to the measurement error correction (MEC) procedure among the *IESO*, the *metering service provider*, and the Registered Professional Engineer.

The steps illustrated in the diagram are described in detail in Section 3.

Table 2–1: Legend for Procedural Work Flow Diagrams

Legend	Description
Oval	An event that triggers task or that completes task. Trigger events and completion events are numbered sequentially within procedure (01 to 99).
Task Box	Shows reference number, party responsible for performing task (if “other party”), and task name or brief summary of task. Reference number (e.g., 1A.02) indicates procedure number within current <i>market manual</i> (1), sub-procedure identifier (if applicable) (A), and task number (02).
Solid horizontal line	Shows information flow between the <i>IESO</i> and external parties.
Solid vertical line	Shows linkage between tasks.
Broken line	Links trigger events and completion events to preceding or succeeding task.

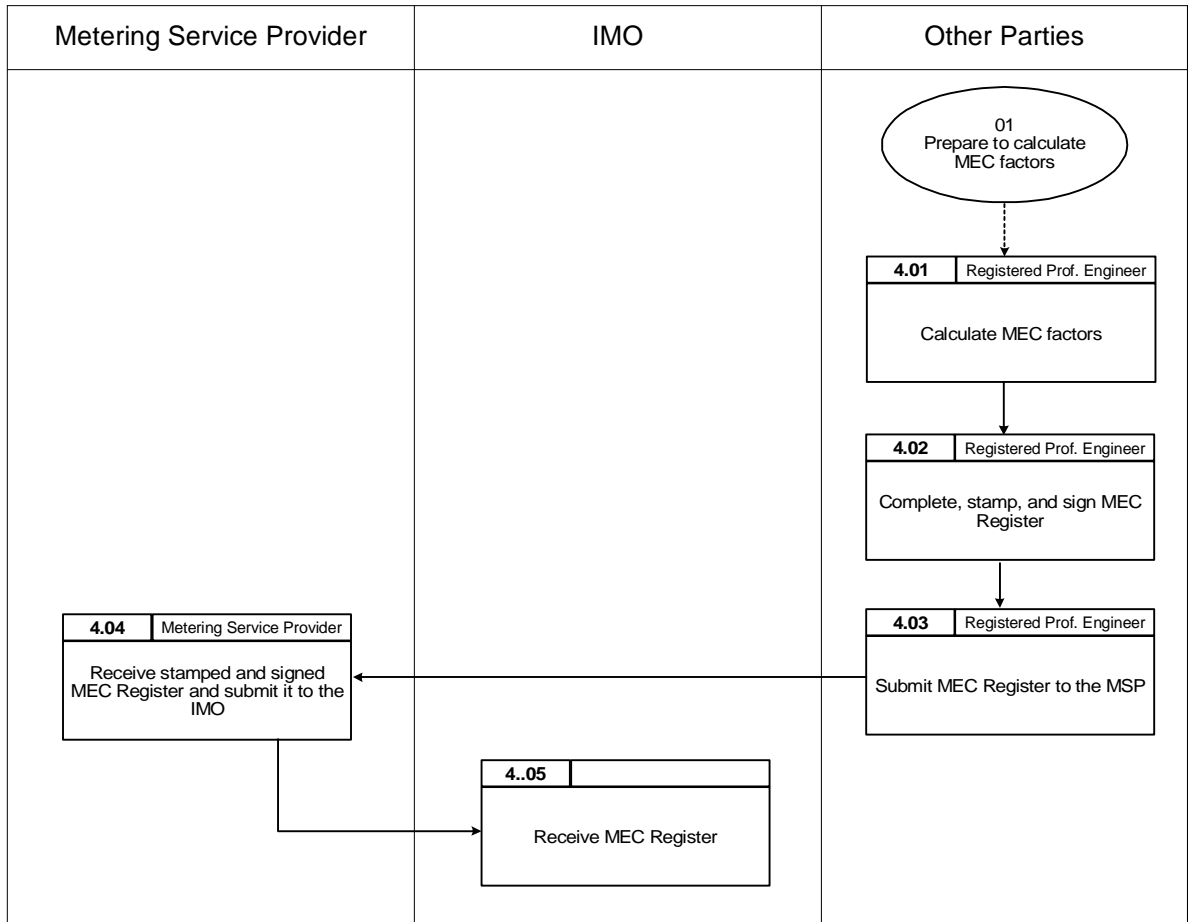

Figure 2–1: Procedural Work Flow for Measurement Error Correction (MEC)

– End of Section –

3. Procedural Steps

This section contains detail on the tasks (steps) that comprise the Measurement Error Correction procedure.

Ref

The numerical reference to the task.

Task Name

The task name as identified in Section 2.

Task Detail

Detail about the task.

When

A list of the information flows that may or must result from the task.

Method

The format and method for each information flow are specified.

Completion Events

A list of all the circumstances in which the task should be deemed finished.

The steps in the following table are illustrated in Section 2:

Table 3–1: Procedural Steps for Measurement Error Correction

Ref.	Task Name	Task Detail	When	Resulting Information	Method	Completion Events
01	Prepare to calculate MEC Factors.	Registered Professional Engineer performs preparatory tasks for MEC factor calculation.	Initial step.			
4.01	Calculate MEC Factors.	<p>Registered Professional Engineer calculates MEC factors according to <i>IESO</i> requirements; the steps are as follows:</p> <ul style="list-style-type: none"> • obtains voltage transformer (VT) and current transformer (CT) ratio correction factors (RCF) and phase angle correction factors (PACF); • calculates cable loss correction factors (CLCF); • calculates final correction factors (FCF); and • calculates final MEC Factors. 		Completes MEC Factor calculations as required by <i>IESO</i> .		MEC Factor calculations completed.
4.02	Complete, stamp, and sign MEC Register.	Registered Professional Engineer completes and signs MEC Register and applies Professional Engineer Ontario (PEO) stamp.	After MEC Factor calculations are complete.	Signed and stamped MEC Register.		MEC Register stamped and signed.

Ref.	Task Name	Task Detail	When	Resulting Information	Method	Completion Events
4.03	Submit MEC Register to <i>metering service provider</i> (MSP).	Registered Professional Engineer submits MEC Register to <i>metering service provider</i> .	After MEC Factor calculations are complete.			
4.04	Receive MEC Register and submit it to the <i>IESO</i> .	<i>Metering service provider</i> receives stamped and signed MEC Register. <i>Metering service provider</i> submits MEC Register to the <i>IESO</i> .	After <i>metering service provider</i> receives MEC Register.		Fax or e-mail; original to follow by regular mail.	
4.05	Receive MEC Register.	<i>IESO</i> receives MEC Register.	After <i>metering service provider</i> submits MEC Register.			

– End of Section –

Appendix A: Forms

This appendix contains a list of the forms and letters associated with the Measurement Error Correction procedure, which are available on the *IESO's* public Web site (<http://www.ieso.ca>). The forms and letters included are as follows:

Form Name	Form Number
Measurement Error Correction Register	IMO-FORM-1039

– End of Section –

Appendix B: Calculation of Error Correction Factors

B.1 Purpose

The data obtained from a revenue *metering installations* may require adjustment for several reasons. Such adjustments are to be operated by applying a measurement error correction (MEC) factor signed and stamped by a Registered Professional Engineer and submitted to the *IESO* by the *metering service provider*.

Among the factors that may require the calculation and submission of MEC factors, the following situations must be considered:

- The secondary cabling attached to the voltage transformer may create a voltage drop that causes the *metering installation* to read low.
- When a *metering installation* is not compliant with Blondel's Theorem, an error correction factor will be required if the magnitude of the error exceeds the limits stated in the *market rules*.
- When the current and voltage transformers connected to the *metering installation* are separated from each other, the *market rules* require a correction factor when the error exceeds stated limits.

In the *IESO-administered markets*, these MEC factors will be applied to the *meter* readings as part of the *settlement process*. Any MEC factors required must be available to the *IESO* when the *metering installation* is registered. If more than one MEC factor is required, they are to be compounded into a single constant adjustment factor.

A standardized set of assumptions for MEC factors is required. This Appendix provides examples for calculating correction factors for *metering installations* that are registered or that are intended to be registered in the *IESO-administered markets*.

B.2 Responsibility for Error Correction Factors

MEC factors shall be calculated, stamped, and signed by a registered professional engineer and submitted to the *IESO* by the *metering service provider*.

B.3 Ratio and Phase Angle Correction Factors

A *metering installation* consists of several components. The measurement error correction factor for each component is separately calculated and errors are combined into a final correction factor (FCF). Distinct FCFs are required for active and reactive power, respectively. The terminology used by this *IESO* procedure *IESO* conforms to that contained in the “Handbook for Electricity Metering”, Edison Electric Institute, 1992.

$$\text{TruePower} = \text{MeasuredPower} \times \text{FCF} \times N_E \times N_I$$

where:

Measured Power is the quantity measured by the *metering installation*

FCF is the final correction factor

N_E is the voltage transformer ratio

N_I is the current transformer ratio

The final correction factor for active power where the *revenue meter* complies with the 0.2 accuracy class of ANSI standard C12.20 is:

$$\text{FCF}_{kW} = \text{RCF}_E \times \text{RCF}_I \times \text{RCF}_L \frac{\cos(q_2 + b - g - g_L)}{\cos(q_2)}$$

where:

RCF_E is the average ratio correction factor for the voltage transformers

RCF_I is the average ratio correction factor for the current transformers

RCF_L is the average correction factor for the voltage transformer lead wires

q_2 is the power factor angle of the measured load as measured by the *meter*

b is the average phase shift in the current transformer, positive when secondary current leads primary current

g is the average phase shift in the voltage transformer, positive when secondary voltage leads primary voltage

g_L is the average phase shift introduced by the lead wires connected to the voltage transformers, positive when voltage at the *meter* leads the voltage at the voltage transformer secondary

For FCF_{kVAR} the cosine function in the FCF_{kW} are replaced by the sine function².

² At this time all MEC for Reactive Power $kVAR$ is not used in the *IESO* system and therefore, may be omitted.

The ratio and phase angle errors for current transformers and voltage transformers are determined by direct measurement, either in the factory at the time of manufacture, or in the field by a qualified service provider.

B.3.1 MEC Factor For A New Metering Installation

A new or upgraded *metering installation* should normally be designed so that the overall measurement error correction factor will equal one (no adjustments to the *meter* readings). The *metering installation* should consist of *instrument transformer* with an 0.3 accuracy class or better, Blondel compliant, no PT to CT separation, secondary cabling (distance, material and cable size), *meters* on the CML, etc.

Ratio correction and phase correction factors are not required for 0.3 accuracy class current and voltage transformers provided that they operate within their rated burden. Since all *instrument transformers* shall operate within their rated burden, the 0.3 accuracy class *instrument transformers* ratio correction and phase angle correction factors are not required, i.e. considered to be equal to one³.

Therefore, the final correction factor for active power can be revised due to the lead wires to be:

$$FCF_{kW} = RCF_L \frac{\cos(q_2 - g_L)}{\cos(q_2)}$$

where:

RCF_L is the average correction factor for the voltage transformer lead wires

q_2 is the power factor angle of the measured load as measured by the *meter*

g_L is the average phase shift introduced by the lead wires connected to the voltage transformers, positive when voltage at the *meter* leads the voltage at the voltage transformer secondary

For FCF_{kVAR} the cosine function in the FCF_{kW} are replaced by the sine function⁴.

The type, size and distance of lead wire can be designed so that the error is less than 0.02%, therefore the MEC value would equal one (no adjustments to the *meter* readings).

The maximum burden for current transformers and voltage transformers must be calculated or measured and become part of the supporting documentation.

³ This paragraph also applies to footnote 1.

⁴ Same as footnote 2

B.3.2 Instrument Transformer Ratio and Phase Angle Errors

The table shown in Figures B-2 illustrates the calculation of MEC factors for *instrument transformers*, based on the actual IT data displayed in Figure B-1. The final correction factor for active power was calculated based on test results determined by direct measurement. Phase angle errors are expressed in both minutes and radians.

The error introduced by the secondary voltage transformer cables is assumed to be less than 0.002% and need not be included in this calculation.

Since the measured current varies within a range from 0.5 to 5 amperes, the FCF is calculated as an average of the FCFs at each test point.

Data for Voltage Transformers and VT Cabling					
RCF				Gamma (Minutes)	
Phase	VT Serial	VT RCF	Cable RCF	VT Gamma	Cable Gamma
A	34564	1.00330	1.00260	12.00	1.18
B	34443	1.00250	0.99961	11.70	-3.13
C	34889	1.00580	0.99943	17.80	2.74

Data for Current Transformers							
Phase	CT Serial	RCF at Secondary Amperes					
		0.5	1.0	2.0	3.0	4.0	5.0
A	23233	1.00580	1.00180	1.00080	1.00020	0.99870	0.98860
B	22334	1.00882	1.00481	1.00380	1.00320	1.00170	0.99157
C	22736	1.01084	1.00682	1.00581	1.00521	1.00370	0.99355
		Beta at Secondary Amperes (Minutes)					
A	23233	-8.00	-4.00	-2.00	-6.00	-7.00	-8.30
B	22334	-8.02	-4.07	-2.01	-6.02	-7.02	-8.32
C	22736	-8.04	-4.08	-2.02	-6.03	-8.50	-8.34

Figure B-1: Instrument Transformer Data

FCF Calculation for Composite VT, CT and Lead Error							
Phase	Amp	0.5	1.0	2.0	3.0	4.0	5.0
A	Ratio Correction Factor						
	VT	1.00330	1.00330	1.00330	1.00330	1.00330	1.00330
	Cable	1.00260	1.00260	1.00260	1.00260	1.00260	1.00260
	CT	1.00580	1.00180	1.00080	1.00020	0.99870	0.98860
	Phase Angle (Minutes)						
	VT γ	12.00	12.00	12.00	12.00	12.00	12.00
	Cable γ_L	1.18	1.18	1.18	1.18	1.18	1.18
	CT β	-8.00	-4.00	-2.00	-6.00	-7.00	-8.30
	$\beta - \gamma - \gamma_L$	-21.18	-17.18	-15.18	-19.18	-20.18	-21.48
	PF θ	1091.69	1091.69	1091.69	1091.69	1091.69	1091.69
	FCF kW	1.01377	1.00936	1.00816	1.00793	1.00652	0.99646
	FCF kVAR	0.99275	0.99238	0.99317	0.98901	0.98664	0.97551
	B	Ratio Correction Factor					
VT		1.00250	1.00250	1.00250	1.00250	1.00250	1.00250
Cable		0.99961	0.99961	0.99961	0.99961	0.99961	0.99961
CT		1.00882	1.00481	1.00380	1.00320	1.00170	0.99157
Phase Angle (Minutes)							
VT γ		11.70	11.70	11.70	11.70	11.70	11.70
Cable γ_L		-3.13	-3.13	-3.13	-3.13	-3.13	-3.13
CT β		-8.02	-4.07	-2.01	-6.02	-7.02	-8.32
$\beta - \gamma - \gamma_L$		-16.59	-12.64	-10.58	-14.59	-15.59	-16.89
PF θ		1091.69	1091.69	1091.69	1091.69	1091.69	1091.69
FCF kW		1.01254	1.00814	1.00694	1.00671	1.00530	0.99525
FCF kVAR		0.99609	0.99566	0.99650	0.99233	0.98995	0.97879
C		Ratio Correction Factor					
	VT	1.00580	1.00580	1.00580	1.00580	1.00580	1.00580
	Cable	0.99943	0.99943	0.99943	0.99943	0.99943	0.99943
	CT	1.01084	1.00682	1.00581	1.00521	1.00370	0.99355
	Phase Angle (Minutes)						
	VT γ	17.80	17.80	17.80	17.80	17.80	17.80
	Cable γ_L	2.74	2.74	2.74	2.74	2.74	2.74
	CT β	-8.04	-4.08	-2.02	-6.03	-8.50	-8.34
	$\beta - \gamma - \gamma_L$	-28.58	-24.62	-22.56	-26.57	-29.04	-28.88
	PF θ	1091.69	1091.69	1091.69	1091.69	1091.69	1091.69
	FCF kW	1.01886	1.01443	1.01322	1.01300	1.01171	1.00146
	FCF kVAR	0.99038	0.99000	0.99086	0.98667	0.98298	0.97318
	Combined FCF kW		1.01506	1.01064	1.00944	1.00921	1.00784
Combined FCF kVAR		0.99308	0.99268	0.99351	0.98934	0.98652	0.97583
Average FCF kW		1.00832					
Average FCF kVAR		0.98849					

Figure B-2: Calculation of MEC Factors for Instrument Transformers and VT Lead Wire

B.3.3 Secondary Wiring Resistance

Secondary lead wiring contributes to the burden imposed on current transformers and introduces additional ratio and phase angle errors on voltage transformers. Figure B-3 below provides the standard resistance per unit length for various wire sizes.

Wire Size (AWG)	Area			Resistance			
				(Ohm/km at 20°C)		(Ohm/1000 ft at 20°C)	
	Sq mm	Sq In	(MCM)	Stranded	Solid	Stranded	Solid
6	13.300	0.020610	26.24	1.3750	1.3484	0.4191	0.4110
8	8.367	0.012970	16.51	2.1860	2.1430	0.6663	0.6532
10	5.261	0.008155	10.38	3.4777	3.4088	1.0600	1.0390
12	3.310	0.005129	6.53	5.5282	5.4134	1.6850	1.6500
14	2.080	0.003225	4.11	8.7894	8.6286	2.6790	2.6300

Figure B-3: Unit Resistance for Various Wire Sizes

The tabulated resistance shall be used for the calculation of secondary burden and of the error correction factors, for ambient temperatures in the cable installation below 20 C. For temperatures that exceed 20 C, the wire resistance shall be temperature corrected to the actual value as shown in the equation below:

$$R_{New} = R_{Tabulated} \times [1 + 0.00393(T_{New} - 20)]$$

where:

T_{New} is in degrees Celsius and must not exceed 120 °C for the equation to apply.

B.3.4 Error Correction for Voltage Transformer Secondary Cabling

The secondary cabling that ensures the connection between the *instrument transformers* and the *meters* may affect the accuracy of the *metering installation*. The error introduced by the secondary cabling must be included in the calculation of the final MEC factors submitted to the *IESO*. This section demonstrates the calculation of MEC factors for voltage transformers.

Secondary cables and lead wires can introduce errors in the voltage values as read by the *metering installation*, in respect to both magnitude and phase angle. The magnitude of these errors depends on the size, material, and length of the wiring used as well as on the amount of current consumed by the *meters*.

Meters are electronic devices that require AC power to operate. If the internal AC power is supplied from a voltage transformer, the voltage drop and phase shift in the secondary cables will be larger than in a case of a *meter* that is powered from an uninterruptible power supply or from a regular AC source, as the high impedance introduced by the latter minimizes the errors.

Manufacturers may specify the burden the *meters* impose on the voltage transformers in two ways. The manufacturer may specify either the input impedance, in ohms, or the active and apparent power required from the voltage transformer. In the first case, of the “high-impedance meters”, MEC factors can be calculated directly, based on the voltage divider principle. If the manufacturer specifies the

load imposed on the voltage transformer in terms of active and reactive power, an iterative approach may be required for the calculation. This method implies an initial guess at the voltage at the *meters*; the calculation of the current in the voltage coils using the assumed voltage value and the value of the power specified by the manufacturer; and the calculation of the voltage drop in the cables based on the calculated current. Eventually, by deducting the voltage drop value from the assumed value of the voltage a new value for the voltage is obtained. The calculation is then repeated based on the new voltage value. The process is repeated until the calculated voltage value stabilizes. The iterative method is illustrated in example 3 which uses a function called “Find” to automate the iteration.

If the voltage drop in the cable is less than 0.3%, an iterative solution can be avoided, as illustrated in Example 2. In this case, a balanced voltage of 120 V is assumed for the voltage transformers. The current in the lead wire is calculated next, by using the assumed voltage value and the rated active and reactive power. The voltage drop introduced by the wiring is then calculated and used for determining the ratio and phase angle error correction factors.

Meters often do not load the voltage transformers equally. Some *meters* may draw more current from one phase than from the others phases. Other *meters* are fitted with true three-phase power supplies that load all three voltage transformers equally.

If the voltage transformers are not loaded equally by the *meter*, ratio and phase angle correction errors must be calculated for each phase. Calculation of separate, ratio and phase angle errors is also required when the length of cable running to voltage transformers differs from phase to phase.

Example 1

Figure B-4 below shows a Main/Alternate *metering installation*, whereby two *meters* are connected to a single set of voltage transformers. The voltage transformers are single-phase 500 kV units mounted in an outdoor switchyard location. The voltage transformer cables run from the red and blue phase units to the white⁵ phase unit and from there into the control building where the *metering installation* is located. The secondary wire is 10 AWG stranded copper.

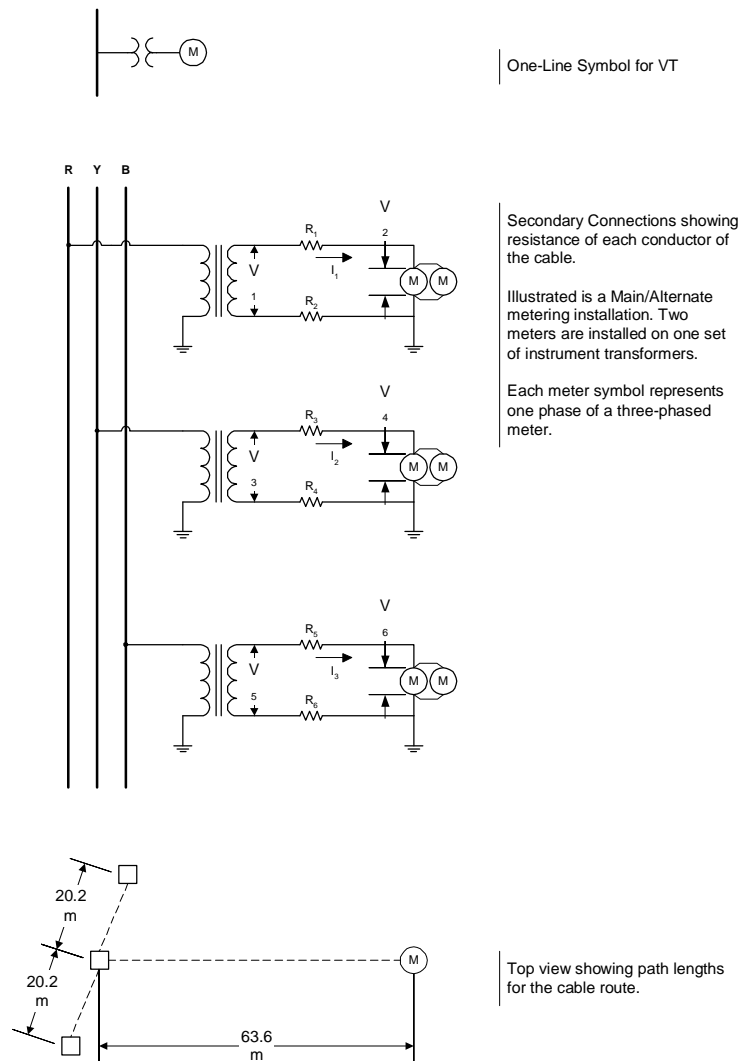

Figure B-4: Connection Diagram for VT's Using Six-Conductor Cabling

⁵ "White" and "yellow" are used interchangeably; both terms refer to the center phase.

The *meters* are identical. The input impedance of each voltage coil is 1.2Megohm. Since the impedance of the *meter* coils is high, no significant ratio or phase angle errors are introduced, as shown by the calculation in Figure B-5 below:

Voltage Transformer Ratio & Phase Angle Calculations: Example 1

$r_{20} = 3.4777 \frac{\text{ohm}}{\text{km}}$		Resistance per unit length for 10 AWG stranded wire at 20 degrees C
$R_1 = (20.2 \text{ m} + 63.6 \text{ m}) r_{20}$	$R_1 = 0.2914\text{ohm}$	Resistance of lead wire for red phase
$R_3 = (63.6 \text{ m}) r_{20}$	$R_3 = 0.2212\text{ohm}$	Resistance of lead wire for white phase
$R_5 = (20.2 \text{ m} + 63.6 \text{ m}) r_{20}$	$R_5 = 0.2914\text{ohm}$	Resistance of lead wire for blue phase
$R_2 = R_1$ $R_4 = R_3$ $R_6 = R_5$		Resistance of lead wire for return wires in each phase
$R_{\text{meter}} = 1.20 \text{ M}\Omega \div 2$	$R_{\text{meter}} = 600.0\text{k}\Omega$	Resistance meter coils in parallel
$V_1 = 120 \text{ V}$	$V_2 = V_1 \left(\frac{R_{\text{meter}}}{R_{\text{meter}} + R_1 + R_2} \right)$	$V_2 = 119.9999\text{V}$
$V_3 = 120 \text{ V}$	$V_4 = V_3 \left(\frac{R_{\text{meter}}}{R_{\text{meter}} + R_3 + R_4} \right)$	$V_4 = 119.9999\text{V}$
$V_5 = 120 \text{ V}$	$V_6 = V_5 \left(\frac{R_{\text{meter}}}{R_{\text{meter}} + R_5 + R_6} \right)$	$V_6 = 119.9999\text{V}$
$\text{RCF}_{L1} = \frac{V_1}{V_2}$	$\text{RCF}_{L1} = 1.000001$	Ratio correction factor for red phase lead wires
$\gamma_{L1} = -\arg\left(\frac{V_1}{V_2}\right)$	$\gamma_{L1} = 0.0000\text{deg}$	Phase shift red phase lead wires
$\text{RCF}_{L2} = \frac{V_3}{V_4}$	$\text{RCF}_{L2} = 1.000001$	Ratio correction factor for white phase lead wires
$\gamma_{L2} = -\arg\left(\frac{V_3}{V_4}\right)$	$\gamma_{L2} = 0.0000\text{deg}$	Phase shift white phase lead wires
$\text{RCF}_{L3} = \frac{V_5}{V_6}$	$\text{RCF}_{L3} = 1.000001$	Ratio correction factor for blue phase lead wires
$\gamma_{L3} = -\arg\left(\frac{V_5}{V_6}\right)$	$\gamma_{L3} = 0.0000\text{deg}$	Phase shift, blue phase lead wires
$\text{FCF}_{\text{kW}} = \frac{1}{3} \left(\frac{\text{RCF}_{L1} \cos(\text{acos}(0.95) - \gamma_{L1})}{0.95} + \frac{\text{RCF}_{L2} \cos(\text{acos}(0.95) - \gamma_{L2})}{0.95} + \frac{\text{RCF}_{L3} \cos(\text{acos}(0.95) - \gamma_{L3})}{0.95} \right)$		
$\text{FCF}_{\text{kW}} = 1.000001$		Final correction factor when VT cables are the only source of error and the power factor is 0.95

Figure B-5: Calculation of MEC Factors for VT Lead Wires Feeding a “High-Impedance” Metering Installation

Example 2

In this example, the high input impedance *meters* are replaced with two *meters* powered from the voltage transformer itself. The voltage coil of each *meter* draws the following loads:

Phase	Watt Loss	VA Loss
Red	12.63	12.75
White	-	-
Blue	0.180	0.194

For this case, the calculation, as shown in Figure B-6 below, is based on a 12 AWG stranded wire.

Voltage Transformer Ratio & Phase Angle Calculations: Example 2

$r_{20} = 5.5282 \frac{\text{ohm}}{\text{km}}$		Resistance per unit length for 12 AWG stranded wire at 20 degrees C
$R_1 = (20.2 \text{ m} + 63.6 \text{ m}) r_{20}$	$R_1 = 0.4633 \text{ ohm}$	Resistance of lead wire for red phase
$R_3 = (63.6 \text{ m}) r_{20}$	$R_3 = 0.3516 \text{ ohm}$	Resistance of lead wire for white phase
$R_5 = (20.2 \text{ m} + 63.6 \text{ m}) r_{20}$	$R_5 = 0.4633 \text{ ohm}$	Resistance of lead wire for blue phase
$R_2 = R_1$ $R_4 = R_3$ $R_6 = R_5$		Resistance of lead wire for return wires in each phase
VA = volt amp VAR = volt amp		Definitions for this spread sheet
$S_1 = 2 \cdot 12.75 \text{ VA} e^{j \cos^{-1} \left(\frac{12.63}{12.75} \right)}$	$S_1 = 25.2600 + 3.4903j \text{ VA}$	Power consumed by two voltage coils on the red phase VT
$S_2 = 0.0 \text{ VA}$	$S_2 = 0.0000 \text{ VA}$	Power consumed by two voltage coils on the white phase VT
$S_3 = 2 \cdot 0.194 \text{ VA} e^{j \cos^{-1} \left(\frac{0.180}{0.194} \right)}$	$S_3 = 0.3600 + 0.1447j \text{ VA}$	Power consumed by two voltage coils on the blue phase VT
$V_2 = 120 \text{ V}$		Voltage at secondary of red phase VT
$V_4 = 120 \text{ V} e^{j -120 \text{ deg}}$		Voltage at secondary of white phase VT
$V_6 = 120 \text{ V} e^{j 120 \text{ deg}}$		Voltage at secondary of blue phase VT
$I_1 = \left(\frac{S_1}{V_2} \right)$	$I_1 = 210.5000 - 29.0861j \text{ mA}$	Current in red phase VT leads
$I_2 = \left(\frac{S_2}{V_4} \right)$	$I_2 = 0.0000 \text{ mA}$	Current in white phase VT leads
$I_3 = \left(\frac{S_3}{V_6} \right)$	$I_3 = -0.4556 + 3.2011j \text{ mA}$	Current in blue phase VT leads
$V_1 = V_2 + I_1 (R_1 + R_2)$	$V_1 = 120.1950 - 0.0269j \text{ V}$	Voltage at secondary of red phase VT
$V_3 = V_4 + I_2 (R_3 + R_4)$	$V_3 = -60.0000 - 103.9230j \text{ V}$	Voltage at secondary of white phase VT
$V_5 = V_6 + I_3 (R_5 + R_6)$	$V_5 = -60.0004 + 103.9260j \text{ V}$	Voltage at secondary of blue phase VT

Figure B-6: Calculation of MEC Factors for Six-Conductor VT Cabling Where AC Supply for the Meter is Provided by the Measuring VT

The ratio and phase angle errors for each phase are as shown in Figure B-7 below:

$$\begin{aligned} \text{RCF}_{L1} &= \left| \frac{V_1}{V_2} \right| & \text{RCF}_{L1} &= 1.001625 & \text{Ratio correction factor for red phase lead wires} \\ \gamma_{L1} &= -\arg\left(\frac{V_1}{V_2}\right) & \gamma_{L1} &= 0.0128 \text{ deg} & \text{Phase shift red phase lead wires} \\ \text{RCF}_{L2} &= \left| \frac{V_3}{V_4} \right| & \text{RCF}_{L2} &= 1.000000 & \text{Ratio correction factor for white phase lead wires} \\ \gamma_{L2} &= -\arg\left(\frac{V_3}{V_4}\right) & \gamma_{L2} &= 0.0000 \text{ deg} & \text{Phase shift white phase lead wires} \\ \text{RCF}_{L3} &= \left| \frac{V_5}{V_6} \right| & \text{RCF}_{L3} &= 1.000023 & \text{Ratio correction factor for blue phase lead wires} \\ \gamma_{L3} &= -\arg\left(\frac{V_5}{V_6}\right) & \gamma_{L3} &= 0.0005 \text{ deg} & \text{Phase shift, blue phase lead wires} \\ \text{FCF}_{\text{kW}} &= \frac{1}{3} \left(\frac{\text{RCF}_{L1} \cos(\text{acos}(0.95) - \gamma_{L1})}{0.95} + \frac{\text{RCF}_{L2} \cos(\text{acos}(0.95) - \gamma_{L2})}{0.95} + \frac{\text{RCF}_{L3} \cos(\text{acos}(0.95) - \gamma_{L3})}{0.95} \right) \\ \text{FCF}_{\text{kW}} &= 1.000575 & & & \text{Final correction factor when VT cables are the only source of error and the power factor is 0.95} \end{aligned}$$

Figure B-7: Calculation of Figure B-6 cont'd

The phase angles are negative because the voltage at the secondary of the voltage transformer lags behind the voltage at the *meter* terminals.

Example 3

In the example illustrated by Figure B-8 below, the breaker layout and cable routing is the same as in the previous examples but a four-wire cable is used to *connect* the voltage transformers instead of the six-conductor cable used previously. The voltage at this 500 kV location is well balanced and no third harmonic current is observed in the common return conductor. The type of the wire installed is 14 AWG, stranded conductor.

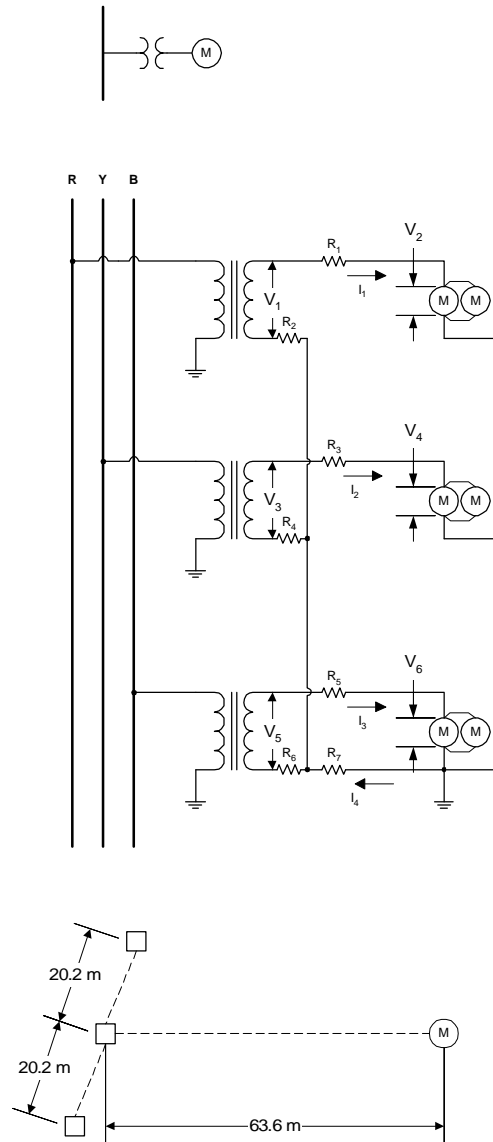

Figure B-8: Metering Installation Using Four-Conductor VT Cabling

The calculations in Figure B-9 below target the voltage drops in the secondary wiring:

Voltage Transformer Ratio & Phase Angle Calculations: Example 3

$r_{20} = 8.7894 \frac{\text{ohm}}{\text{km}}$		Resistance per unit length for 14 AWG stranded wire at 20 degrees C
$R_1 = (20.2 \text{ m} + 63.6 \text{ m}) r_{20}$	$R_1 = 0.7366 \text{ ohm}$	Resistance of lead wire for red phase
$R_3 = (63.6 \text{ m}) r_{20}$	$R_3 = 0.5590 \text{ ohm}$	Resistance of lead wire for white phase
$R_5 = (20.2 \text{ m} + 63.6 \text{ m}) r_{20}$	$R_5 = 0.7366 \text{ ohm}$	Resistance of lead wire for blue phase
$R_2 = r_{20} 20.2 \text{ m}$	$R_2 = 0.1775 \text{ ohm}$	Resistance of lead wire
$R_4 = r_{20} 0.0 \text{ m}$	$R_4 = 0.0000 \text{ ohm}$	Resistance of lead wire
$R_6 = r_{20} 20.2 \text{ m}$	$R_6 = 0.1775 \text{ ohm}$	Resistance of lead wire
$R_7 = r_{20} 63.6 \text{ m}$	$R_7 = 0.5590 \text{ ohm}$	Resistance of lead wire
$S_2 = 2 \cdot 12.75 \text{ VA} e^{j \arccos\left(\frac{12.63}{12.75}\right)}$	$S_2 = 25.2600 + 3.4903j \text{ VA}$	Power consumed by two voltage coils on the red phase VT
$S_4 = 0.0 \text{ VA}$	$S_4 = 0.0000 \text{ VA}$	Power consumed by two voltage coils on the white phase VT
$S_6 = 2 \cdot 0.194 \text{ VA} e^{j \arccos\left(\frac{0.180}{0.194}\right)}$	$S_6 = 0.3600 + 0.1447j \text{ VA}$	Power consumed by two voltage coils on the blue phase VT
$V_1 = 120 \text{ V}$		Voltage at secondary of red phase VT
$V_3 = 120 \text{ V} e^{j 240 \text{ deg}}$		Voltage at secondary of white phase VT
$V_5 = 120 \text{ V} e^{j 120 \text{ deg}}$		Voltage at secondary of blue phase VT

$$\begin{pmatrix} V_1 \\ V_3 \\ V_5 \end{pmatrix} = \begin{pmatrix} R_1 + R_2 + R_7 & R_7 & R_7 \\ R_7 & R_3 + R_4 + R_7 & R_7 \\ R_7 & R_7 & R_5 + R_6 + R_7 \end{pmatrix} \begin{pmatrix} I_1 \\ I_2 \\ I_3 \end{pmatrix} + \begin{pmatrix} V_2 \\ V_4 \\ V_6 \end{pmatrix} \quad \text{Mesh equation to be solved}$$

Figure B-9: Calculation of MEC Factors for Four-Conductor VT Cabling Where AC Supply for the Meter is Provided by the Measuring VT

The ratio and phase angle errors introduced by the secondary voltage transformer cabling are calculated in Figure B-10 below:

$V_2 = V_1$	$V_4 = V_3$	$V_6 = V_5$	Initial guess at solution
Given			
$\begin{pmatrix} V_1 \\ V_3 \\ V_5 \end{pmatrix} = \begin{pmatrix} R_1 + R_2 + R_7 & R_7 & R_7 \\ R_7 & R_3 + R_4 + R_7 & R_7 \\ R_7 & R_7 & R_5 + R_6 + R_7 \end{pmatrix} \begin{pmatrix} \frac{S_2}{V_2} \\ \frac{S_4}{V_4} \\ \frac{S_6}{V_6} \end{pmatrix} + \begin{pmatrix} V_2 \\ V_4 \\ V_6 \end{pmatrix}$		Mesh equation with current replaced by power and voltage at meter	
$\begin{pmatrix} V_2 \\ V_4 \\ V_6 \end{pmatrix} = \text{Find}(V_2, V_4, V_6)$		Interactive calculation of voltage at each VT	
$V_2 = 119.689348 + 0.041063jV$		Calculated voltages at the meters	
$V_4 = -60.117726 - 103.908576jV$			
$V_6 = -60.117307 + 103.934597jV$			
$RCF_{L1} = \left \frac{V_1}{V_2} \right \quad RCF_{L1} = 1.002595$		Ratio Correction factor for red phase lead wires	
$\gamma_{L1} = -\arg\left(\frac{V_1}{V_2}\right) \quad \gamma_{L1} = 1.18 \text{ min}$		Phase shift red phase lead wires	
$RCF_{L2} = \left \frac{V_3}{V_4} \right \quad RCF_{L2} = 0.999614$		Ratio correction factor for white phase lead wires	
$\gamma_{L2} = -\arg\left(\frac{V_3}{V_4}\right) \quad \gamma_{L2} = -3.13 \text{ min}$		Phase shift white phase lead wires	
$RCF_{L3} = \left \frac{V_5}{V_6} \right \quad RCF_{L3} = 0.999428$		Ratio correction factor for blue phase lead wires	
$\gamma_{L3} = -\arg\left(\frac{V_5}{V_6}\right) \quad \gamma_{L3} = 2.74 \text{ min}$		Phase shift, blue phase lead wires	
$FCF_{kW} = \frac{1}{3} \left(\frac{RCF_{L1} \cos(\text{acos}(0.95) - \gamma_{L1})}{0.95} + \frac{RCF_{L2} \cos(\text{acos}(0.95) - \gamma_{L2})}{0.95} + \frac{RCF_{L3} \cos(\text{acos}(0.95) - \gamma_{L3})}{0.95} \right)$			
$FCF_{kW} = 1.000571$		Final correction factor when VT cables are the only source of error and the power factor is 0.95	

Figure B-10: Calculation of Figure B-9 cont'd

B.4 Non-Blondel Compliant Metering Installations

New *metering installations* must comply with Blondel's Theorem and thus must provide accurate *metering data* under all conditions of voltage or current unbalance.

Non-Blondel compliant *metering installations* that are in service on April 17, 2000 or, that are the subject of an application for registration prior to the *market commencement date* and for which major components were ordered or procured on or before May 17, 2000 will be considered for registration. This section outlines the principles to be applied when developing error correction factors for purposes of registering a non-Blondel compliant *metering installation*.

Both ANSI and CSA require transformers to have standardized impedance at specified MVA ratings. Transformers in the range of 1 MVA to 10 MVA are required to have short circuit impedance between 5 and 6.25%. Given the narrow range of impedance for each class, the method demonstrated in this section may be used to estimate the worst case errors for an entire class of power transformers, thereby reducing the effort involved in estimating metering error to looking up a value in a table.

There are many forms of non-compliance, in addition to those illustrated in this section. Every *metering installation* must be considered on its own merits and this section provides uniform requirements for estimating metering errors for the most frequently occurring cases only.

B.4.1 Error Limits

The *market rules* require the application of error correction factors when a *metering installation* that does not comply with Blondel's Theorem has a magnitude of maximum error that exceeds the limits referred to in Appendix 6.2 of the *market rules*. The requirements are as follows:

Maximum Error Range	Action
0 - 0.2%	No correction factor required
>0.2 - 3%	Error correction factor required
Over 3%	Error correction factor required and <i>metering installation</i> must be upgraded to comply with Blondel's Theorem

B.4.2 Basis for Error Calculations

Metering installations that do not comply with Blondel's Theorem operate correctly only when the voltages and currents in the system are balanced. At system level, there is also a strong correlation between the current and the voltage unbalance, a correlation dependent on the system impedance. If the symmetrical component impedances are known, a worst-case load unbalance can be assumed and the resulting metering error calculated.

In the case of four wire *distribution systems*, the worst-case combination of per phase loads and power factors can seldom be determined in advance. In such cases, a Monte Carlo simulation may be used to apply randomly selected loads at randomly selected power factors to each phase to enable the calculation of the resulting metering error.

B.4.3 Types of Non-Conforming Installations

Registration of a non-Blondel *metering installation* requires a non-Blondel measurement error correction factor to be calculated and submitted to the *IESO* for approval. The “Wholesale Revenue Metering Standard – Hardware”, Section 4.3.3 describes the various non-Blondel *metering installations* that will be considered for registration and Section 4.4.2 describes the MEC requirements.

Metering installations that do not conform with Blondel’s Theorem include:

1. Two and one half element *metering installations* – using three current transformers, two voltage transformers connected phase to ground and a two and one-half element *meter* (“Wholesale Revenue Metering Standard – Hardware”, Section 4.3.3.a).

The measurement error correction for this type of *metering installation* can be calculated using two methods:

a) The maximum error, caused by the unbalanced voltage, may be determined as the product of the maximum sustained residual voltage⁶ times the maximum current in the phase without a voltage transformer divided by the power that would be measured by a *metering installation* at the same location that does comply with Blondel’s Theorem.

b) For certain types of installations, where the Thévenin impedance is known and the high voltage system voltages are balanced, the maximum residual voltage may be determined from the maximum residual current. A Monte Carlo simulation may be used to plot the errors associated with a large sample of randomly unbalanced loads. The envelope of the error plot provides the required relation between neutral current and metering error. Refer to Section B.4.5 of this Appendix for an example of these calculations.

2. Two-and one-half-element *metering installations* – using three delta connected current transformers, two voltage transformers connected phase to ground and a two-element *meter* (“Wholesale Revenue Metering Standard – Hardware”, Section 4.3.3.b).

This type of *metering installation* is a variation of the two-and one-half-element *metering installation* described above (B.4.3 – 1.) and exhibits the same errors. Refer to Section B.4.5 for an example of these calculations.

3. Delta metering of transmission or distribution circuits – using two current transformers, three voltage transformers connected phase-to-ground with 69V secondaries and a two-element *meter* (“Wholesale Revenue Metering Standard – Hardware”, Section 4.3.3.c).

a) If the *metering installation* is located on the high voltage delta-connected winding of a power transformer above 50 kV, it is considered as accurate as a two-element *metering installation* using two current transformers, two phase-to-phase connected voltage transformers and a two-element *meter* at the same location. As a result, the non-Blondel MEC factor is 1.0000.

b) If the *metering installation* is located on the high voltage wye-grounded connected winding of a power transformer, the MEC factor is calculated as follows:

- The maximum error may be determined as the product of the maximum sustained neutral current⁷ and the maximum phase-to-neutral voltage divided by the power that

⁶ The residual voltage is the phasor sum of the three line-to-neutral voltages, equivalent to three times the zero sequence voltage.

⁷ This value is often determined by protective relay settings.

would be measured by a *metering installation* at the same location that does comply with Blondel's Theorem.

Figure B–11 illustrates the MEC calculation where a 230 kV system operates at 241 kV and carries 950 amperes. The neutral current on the CT primary is 12.2 amperes.

$$P_{\text{true}} = \sqrt{3} \, 241 \times \text{kV} \, 955 \, \text{amp} \quad P_{\text{true}} = 398.640 \, \text{MW}$$

$$P_{\text{dif}} = 241 \, \text{kV} \times 12.2 \, \text{amp} \div \sqrt{3} \quad P_{\text{dif}} = 1697.525 \, \text{kW}$$

$$\text{Error} = \frac{(P_{\text{true}} + P_{\text{dif}}) - P_{\text{true}}}{P_{\text{true}}} \quad \text{Error} = 0.426 \%$$

Figure B-11: Calculation of MEC Factors for a Delta-Metered Transmission Line

The *metering installation* may be upgraded to Blondel compliant by installing the third CT and replacing the two-element *meter* with a three-element *meter* rated at 69V.

4. Two-element *metering installation* located at the transformer station where the power system neutral/ground is available but not used – using two current transformers and two voltage transformers connected phase to phase and a two-element *meter*. (“Wholesale Revenue Metering Standard – Hardware”, Section 4.3.3.d)

This type of *metering installation* is typically used on uni-grounded systems and supplies ungrounded loads.

The maximum error may be determined as the product of the maximum sustained neutral current and the maximum phase-to-neutral voltage divided by the power that would be measured by a *metering installation* at the same location that does comply with Blondel's Theorem, as previously illustrated.

5. Two-element metering of a *generation facility* where a grounded *generator* is connected to a grounded winding of the step up power transformer. The *metering installation* is located between the *generation unit* and the step up power transformer. All load connections between the *generation unit* and the *metering installation* are delta connected – using two current transformers and two voltage transformers connected phase-to-phase and a two-element *meter* (“Wholesale Revenue Metering Standard – Hardware”, Section 4.3.3.e).

The maximum error may be determined as the product of the maximum sustained neutral current⁸ and the maximum phase-to-neutral voltage divided by the power that would be measured by a *metering installation* at the same location that conforms with Blondel's Theorem, as described in section B.4.3-3.

⁸ This value is often determined by protective relay settings.

B.4.4 Significant differences between VT and CT primary voltage due to physical installation

In order to ensure an accurate power flow measurement, the current transformers (CTs) and voltage transformers (VTs) pertaining to a *metering installation* should be connected, as much as possible, to the same physical point. However, actual conditions may prevent an ideal installation, thus translating into a certain length of bus or overhead conductor being present between the system points at which the CTs and VTs are connected. This section details the calculation of the error correction factors required by the CTs and VTs being installed at significantly different physical points.

The error in this case is caused by the voltage drop between the current and the voltage transformer and can be calculated from the phasor representing this voltage drop. The voltage drop is calculated on the assumption of 1 per unit voltage at the current transformer location and the assumption of maximum power flow at the current transformer location. For *generators*, the maximum power flow represents the maximum apparent power output of the unit. For loads, the maximum power flow is considered to be 1.5 times higher than the rated apparent power. In the case of a ring bus configuration, where the direction of power flow may reverse, the calculation will be based on the worst case scenario.

The power at the voltage transformer location is calculated based on the impedance of the circuit between the CTs and VTs and the assumed power flow. The phasor voltage at the voltage transformer location is obtained by adding the voltage drop to the assumed voltage at the CT location. Multiplying the current at the CT location by the voltage at the VT location results in the phasor power measured by the *meter*. By comparing this value to the power at the CT location the required error correction factor can be determined. To ensure that all *market participants* calculate this MEC factor the same way, a number of standardized assumptions regarding the conductor temperature and load are required. Such are:

- Conductors are assumed to be functioning at 50 °C.
- Loads are assumed to be 1.5 times the rated apparent power of the power transformer
- *Generators* are assumed to be operating at maximum apparent power output
- The worst case value for the power factor must be assumed. For loads, this is the lowest power factor that has been observed or that can be expected. For *generators*, the worst power factor is the one correspondent to the point on the operating curve that results in maximum apparent power.
- For a ring bus configuration, the positions of various switches will be considered as to maximize the voltage difference between the current transformer and voltage transformer.

Example

The Figure B-12 below illustrates the case of a delta-wye transformer that is metered by means of a *metering installation* whereby the component CTs and VTs are installed 251 feet apart, the conductor between the two locations being 795 MCM Aluminum. The power transformer ratings are 30 MVA and 44/8.32 kV. The lowest power factor observed to date is 92%. The conductor impedance is calculated from the standard tables as specified by the SSLA Standard. In this particular case, the “Westinghouse Electric Utility Engineering Reference Book Volume 3” was used as reference.

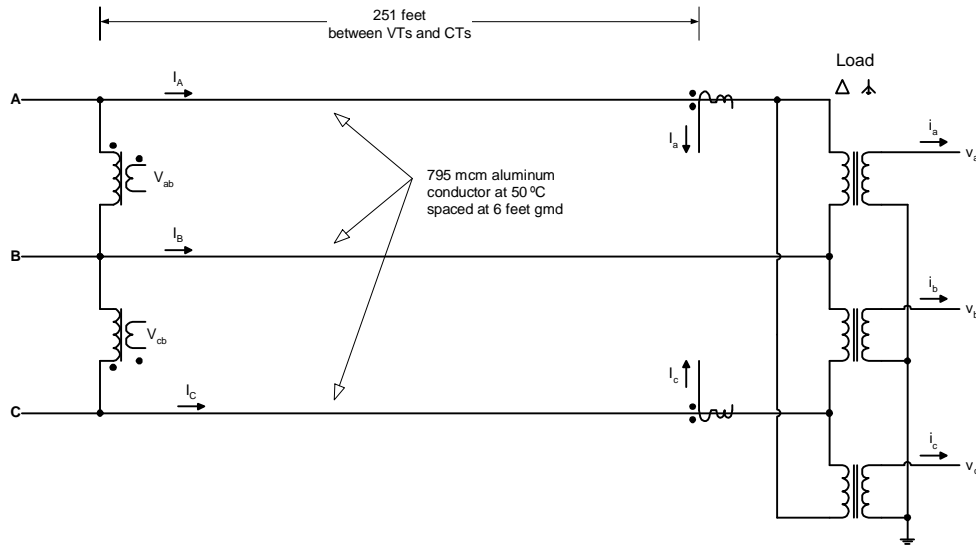

Figure B-12: Connection Diagram Illustrating the Physical Separation of Instrument Transformers

The calculation shows that the error introduced in terms of active power by the physical distance between the installation points of the CTs and VTs is less than 0.02%. Hence, no active power correction factor is required. In the case of reactive power, the error exceeds the 0.02% limit of the *market rules* and thus a correction factor is indeed required.

The symbols used throughout the calculation of the error correction factors are as defined in Figure 13 below.

- A, B, C represent the phase conductors
- I_A, I_B, I_C represent the primary load current
- i_a, i_b, i_c represent the current supplied to the *meter*
- V_{ab}, V_{cb} represent the voltage supplied to the *meter*

Figure B-13: Meaning of Symbols Used in the Calculations in Figures 14 and 15

The detailed calculations are illustrated in Figures B-14 and B-15 below.

Calculation of Measurement Error Due to Separation of CTs and VTs

Worst Case Power Factor: $pf = 0.92$ Lag

Power Factor Angle: $\theta = \cos^{-1}(pf) \quad \theta = 23.074\text{deg}$

Voltages at CTs: $V_{ABct} = 44.0 e^{j 60 \text{ deg}} \text{ kV} \quad V_{CBct} = 44.0 e^{j 120 \text{ deg}} \text{ kV}$

Maximum Load Current: $I_{\max} = 1.5 \left(\frac{30 \text{ MVA}}{\sqrt{3} 44.0 \text{ kV}} \right) \quad I_{\max} = 590.472 \text{ A}$

Currents at CTs and VTs: $I_A = I_{\max} e^{j (30 \text{ deg} - \theta)} \quad I_C = I_{\max} e^{j (150 \text{ deg} - \theta)} \quad I_B = -(I_A + I_C)$

Check Assumptions:

Phasor Power: $V_{ABct} \overline{I_A} + V_{CBct} \overline{I_C} = 41.400 + 17.636j \text{ MVA}$

Scalar Power: $\sqrt{3} (44 \text{ kV}) I_{\max} \cos(\theta) = 41.400 \text{ MW} \quad \text{Ok}$

$\sqrt{3} (44 \text{ kV}) I_{\max} \sin(\theta) = 17.636 \text{ MVAR} \quad \text{Ok}$

Impedance of Conductor from Westinghouse Electric Utility Engineering Reference Book Volume :
Note: Shunt reactance (capacitance) is ignored.

For 795 mcm 37 strand aluminum at 50° C: $r_a = 0.131 \frac{\text{ohm}}{\text{mile}} \quad x_a = 0.4146 \frac{\text{ohm}}{\text{mile}}$

For 6 foot conductor spacing (GMD): $x_d = 0.2174 \frac{\text{ohm}}{\text{mile}}$

Positive sequence impedance: $Z_{\text{Line}} = [r_a + j(x_a + x_d)] 251 \text{ ft} \quad Z_{\text{Line}} = 6.227 + 30.044j \text{ mOhm}$

Voltage at VTs: $V_{ABvt} = V_{ABct} + (I_A - I_B) Z_{\text{Line}} \quad V_{CBvt} = V_{CBct} + (I_C - I_B) Z_{\text{Line}}$

Power measure by metering: $S_{\text{meas}} = V_{ABvt} \overline{I_A} + V_{CBvt} \overline{I_C} \quad S_{\text{meas}} = 41.407 + 17.668j \text{ MVA}$

Power at CTs: $S_{\text{true}} = V_{ABct} \overline{I_A} + V_{CBct} \overline{I_C} \quad S_{\text{true}} = 41.400 + 17.636j \text{ MVA}$

Figure B-14: Calculation of MEC Factors Required by the Physical Separation of CTs and VTs

Calculation of Correction Factors:

$$P_{\text{meas}} = \text{Re}(S_{\text{meas}}) \quad P_{\text{meas}} = 41.407\text{MW}$$

$$P_{\text{true}} = \text{Re}(S_{\text{true}}) \quad P_{\text{true}} = 41.400\text{MW}$$

$$\text{Measurement Error for Watts: } \text{Error}_{\text{kW}} = \frac{P_{\text{meas}} - P_{\text{true}}}{P_{\text{true}}} \quad \text{Error}_{\text{kW}} = 0.0157\%$$

$$\text{Correction Factor for Watts: } \text{MECF}_{\text{kW}} = \frac{P_{\text{true}}}{P_{\text{meas}}} \quad \text{MECF}_{\text{kW}} = 0.999843$$

$$Q_{\text{meas}} = \text{Im}(S_{\text{meas}}) \quad Q_{\text{meas}} = 17.668\text{MVAR}$$

$$Q_{\text{true}} = \text{Im}(S_{\text{true}}) \quad Q_{\text{true}} = 17.636\text{MVAR}$$

$$\text{Measurement Error for Watts: } \text{Error}_{\text{kVAR}} = \frac{Q_{\text{meas}} - Q_{\text{true}}}{Q_{\text{true}}} \quad \text{Error}_{\text{kVAR}} = 0.1782\%$$

$$\text{Correction Factor for Watts: } \text{MECF}_{\text{kVAR}} = \frac{Q_{\text{true}}}{Q_{\text{meas}}} \quad \text{MECF}_{\text{kVAR}} = 0.998221$$

Conclusions:

1. No correction factor is required for active power (watts) since the error is less than the 0.02% specified in the market rules.
2. An error factor is required to correct for reactive power since the error introduced by the separation of the VTs and CTs exceeds 0.02%. The factor 1.001782 would be to the IESO for reactive power in this

Figure B-15: Calculation of Figure 14 cont'd

B.4.5 Example Error Calculation For 2 ½ Element Metering

For this example, a 6 MVA power transformer supplies a *distribution system* at 13.8 kV. The transformer has a delta primary and the primary supply voltage is balanced. The secondary is wye, solidly grounded with a 2½ element *metering installation* supplying an unbalanced four wire load.

The sequence impedance of the power transformer is 1.1+j5.31% and zero sequence impedance is 0.73+j4.00%. The power transformer is protected by ground fault over current relaying with the tripping point set at 75 amperes.

The loading and power factor on each phase varies from day to day in an unpredictable pattern.

Figure B-16 below illustrates execution of a Monte Carlo simulation by a graphical spread sheet program. The program randomly selects a load current ranging from 0 to 1.5 per unit (pu) to be

applied to each phase of the secondary winding. Next the program selects a random power factor in the range 0.9 to 1.0 for each phase. Now that the current in each phase is known, the voltage is calculated on each phase based on the sequence impedance.

Number of unbalances required:	$k = 0..30000$	
Sym Comp Operator:	$\alpha = e^{j 120 \text{ deg}}$	
Thevenin Voltages:	$\text{pu} = 1$	$E_a = 1 \text{ pu}$ $E_b = \alpha^2 \text{ pu}$ $E_c = \alpha \text{ pu}$
Thevenin Impedance:	$Z_1 = (0.011 + j 0.0531) \text{ pu}$	$Z_0 = (0.0073 + j 0.040) \text{ pu}$
	$ Z_1 = 5.42\%$	$ Z_0 = 4.07\%$
Voltage Functions:	$V_a(I_a, I_b, I_c) = E_a - \frac{1}{3} (Z_0 + 2 Z_1) I_a - \frac{1}{3} (Z_0 - Z_1) (I_b + I_c)$ $V_b(I_a, I_b, I_c) = E_b - \frac{1}{3} (Z_0 + 2 Z_1) I_b - \frac{1}{3} (Z_0 - Z_1) (I_a + I_c)$ $V_c(I_a, I_b, I_c) = E_c - \frac{1}{3} (Z_0 + 2 Z_1) I_c - \frac{1}{3} (Z_0 - Z_1) (I_b + I_a)$	
Array of Phase Currents:	$I_{a_k} = 1.5 \text{ rnd}(1) e^{j(-\text{acos}(0.9+0.1 \text{ rnd}(1)))} \text{ pu}$ $I_{b_k} = 1.5 \alpha^2 \text{ rnd}(1) e^{j(-\text{acos}(0.9+0.1 \text{ rnd}(1)))} \text{ pu}$ $I_{c_k} = 1.5 \alpha \text{ rnd}(1) e^{j(-\text{acos}(0.9+0.1 \text{ rnd}(1)))} \text{ pu}$	Phase currents range randomly from 0 to 1.5 pu at random power factors ranging from 0.9 to 1.0.
Array of Results:	$S_{\text{true}_k} = V_a(I_{a_k}, I_{b_k}, I_{c_k}) \overline{I_{a_k}} + V_b(I_{a_k}, I_{b_k}, I_{c_k}) \overline{I_{b_k}} + V_c(I_{a_k}, I_{b_k}, I_{c_k}) \overline{I_{c_k}} \text{ pu}$	
Residual Voltage:	$V_{R_k} = V_a(I_{a_k}, I_{b_k}, I_{c_k}) + V_b(I_{a_k}, I_{b_k}, I_{c_k}) + V_c(I_{a_k}, I_{b_k}, I_{c_k})$	
Calculate Errors:	$\text{Error}_k = \frac{-V_{R_k} \overline{I_{b_k}}}{S_{\text{true}_k}}$	(pu) Real part = kW error, Imaginary part = kVAR error
Develop Quantities for Plotting:	$V_{\text{Res}_k} = V_{R_k} $ $\text{kW}_{\text{Error}_k} = \text{Re}(\text{Error}_k)$	Magnitude of residual voltage in pu pu error in measurement of active power
Limits Inferred from Error Plots:	$\text{HiLim}_k = 0.62 V_{\text{Res}_k}$ $\text{LoLim}_k = -0.42 V_{\text{Res}_k}$	
Equation for Residual Current:	$I_{\text{Res}} = \frac{ V_{\text{Res}} }{ Z_0 }$	$\frac{1}{ Z_0 } = 24.5938$

Figure B-16: Calculation of MEC Factors for a Two-and-a-Half Element Metering Installation Measuring a Wye-Connected Power Transformer

Next, the residual voltage and the metering error are calculated. The metering error is then plotted against the residual voltage. This process is repeated enough times for the envelope of the scatter plot to be determined. In this example, 30,000 test points are plotted.

In the case of a 2½ element *metering installation*, the error for each random loading can be shown as a function of residual voltage:

$$\text{Error} = \frac{-V_R \cdot \overline{I_b}}{S_{\text{true}}}$$

Where: Error is the percent error of the measurement

V_R is the residual voltage, a complex number

I_b is the current in the phase lacking a current transformer; the bar operator is the complex conjugate operator

S_{true} is the measurement that a three-element metering would have made, also a complex number.

Figure B-17 below shows the resulting scatter plot. The metering error will range from -3% to +5%. The upper branch of the envelope is steeper than the lower branch and forms the worst-case limit line. The two horizontal lines in the figure mark the ±0.2% error limits.

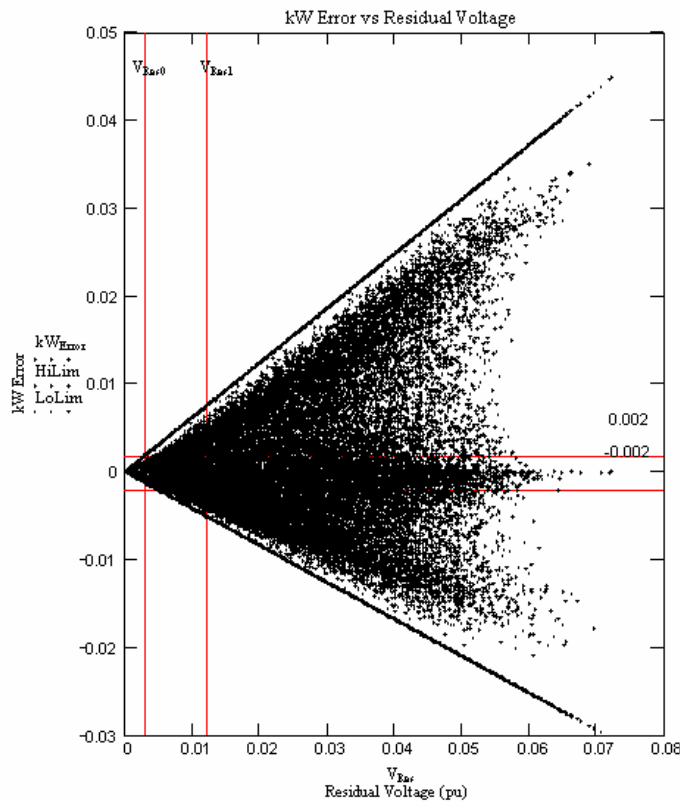

Figure B-17: Graph Illustrating the Distribution of Errors Calculated in Figure B-16

Figure B-18 below shows a close-up of the error plot, focussing on the region near the origin. It indicates that as long as the residual voltage is less than 0.003077 pu of rated line-to-neutral voltage, the metering error for active power will be less than 0.2% and no correction factor will be required.

While residual voltage is difficult to measure in the field, residual current can easily be measured using an ammeter to record the current flowing in the X0 bushing of the power transformer. In most outdoor installations, the X0 bushing is grounded through an insulated conductor. A clip-on ammeter can be used to spot check the X0 current.

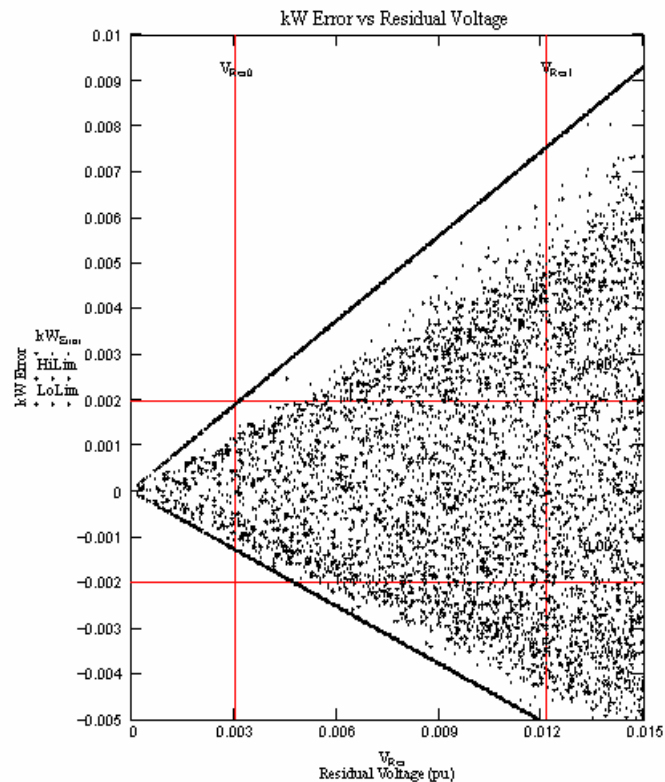

Figure B-18: Exploded Area for the Graph Shown in Figure 17

Figure B-19 below reflects the fact that residual voltage and residual current are tightly correlated by the zero-sequence impedance. The Figure indicates that as long as the residual current does not exceed 0.0757 pu (19.00 amp), the error will be less than 0.2%. On the other hand, if the maximum residual current exceeds 19 A, a MEC will be required. In the case of the *metering installation* shown in Figure 19, the neutral current frequently exceeds 19 A while is being limited by protective relaying to 75 A (0.2988 pu).

The *IESO* will therefore also apply an error correction factor of 0.7532% in this case, based on the slope of the branch of the scatter diagram with the steepest slope. Because this is a load, the *IESO* will increase the consumption by a constant 0.7532%. If the site used in the example were a *generation facility*, the output would be reduced by 0.7532%.

The measurement error correction factor for the *metering installation* used in this particular example will be 1.007532.

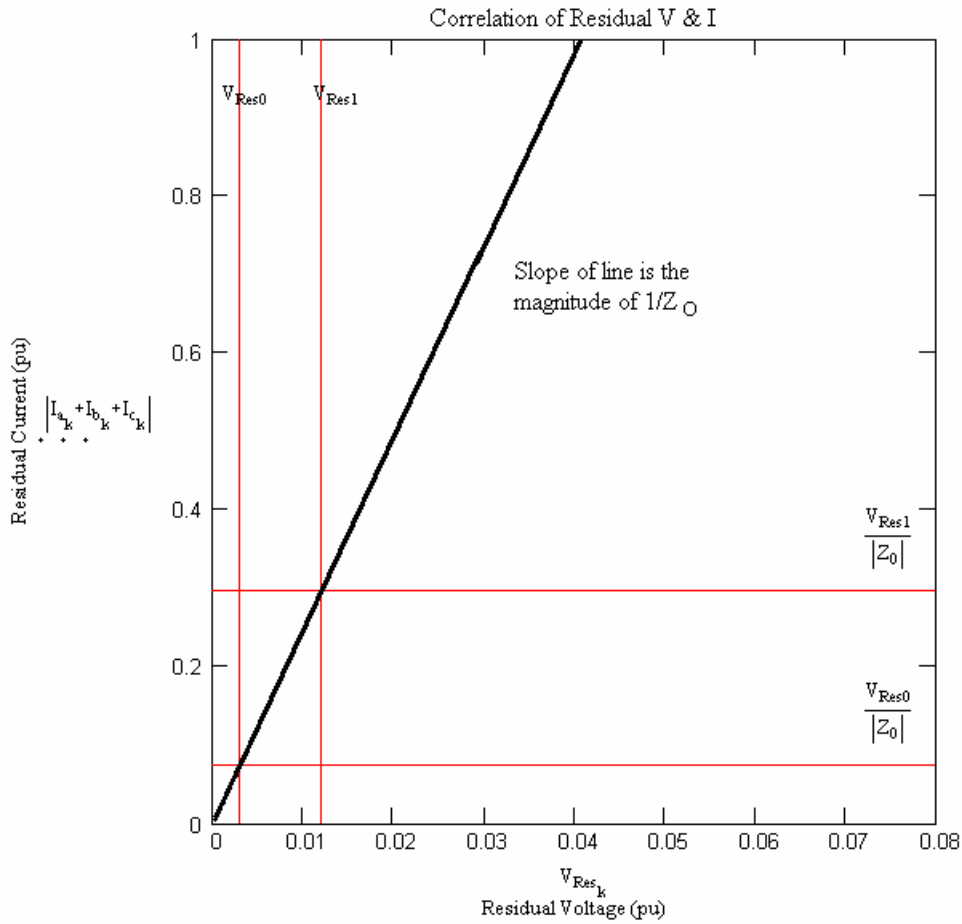

Figure B-19: Residual Voltage Versus Residual Current Graph

For a similar installation, but for a *generation facility*, the calculation of the error correction factor is given in the Figure B-20 below.

For a 6 MVA 44/13.8 kV D-Yg Power Transformer:

Maximum residual voltage (in percent) requiring no correction factor.	$V_{Res0} = \frac{0.2\%}{0.65}$	$V_{Res0} = 0.003077 \text{ pu}$
Rated Current:	$I_{Rated} = \frac{6000 \text{ kW}}{\sqrt{3} \times 13.8 \text{ kV}}$	$I_{Rated} = 251.02 \text{ amp}$
Max current on X0 bushing for no correction factor	$I_{ResMax0} = I_{Rated} \frac{V_{Res0}}{ Z_0 }$	$I_{ResMax0} = 19.00 \text{ amp}$
Maximum residual current possible:	$I_{ResMax1} = \frac{75 \text{ amp}}{I_{Rated}}$	$I_{ResMax1} = 0.2988 \text{ pu}$
Residual voltage at $I_{ResMax1}$	$V_{Res1} = I_{ResMax1} Z_0 $	$V_{Res1} = 1.2149 \%$
kW Error at maximum residual current:	$kW_{Error1} = 0.62 V_{Res1}$	$kW_{Error1} = 0.7532 \%$
Correction factor for Loads	$CF_{Load} = 1 + kW_{Error1}$	$CF_{Load} = 1.007532$
Correction factor for generators	$CF_{Gen} = 1 - kW_{Error1}$	$CF_{Gen} = 0.992468$

Figure B-20: Calculation of MEC Factors for a Two-and-a-Half Element Metering Installation Measuring a Wye-Connected Power Transformer

The calculations above have demonstrated how the measurement error correction factor may be determined for *metering installations* that do not comply with Blondel's Theorem. However, this is not the only method that can be applied. If a single worst-case unbalance can be determined ahead of time, the measurement error correction factor may be calculated without employing the Monte Carlo simulation but by using the principles described in Section B.4.3 above.

Generally, the *IESO* will accept any method of calculation based on sound engineering principles and valid assumptions regarding the worst-case unbalance that may occur.

Once the measurement error correction factor is known, the *market participant* can easily determine the economic benefit of upgrading the *metering installation* such that it complies with Blondel's Theorem.

– End of Section –

References

Document ID	Document Title
MDP_MAN_0003	Market Manual 3, Metering, Part 3.0: Metering Overview
MDP_PRO_0013	Market Manual 3: Metering, Part 3.2: Meter Point Registration and Maintenance
MDP_RUL_0002	Market Rules
MDP-STD-0004	Wholesale Revenue Metering Standard – Hardware
IMP_PRO_0047	Market Manual 3: Metering, Part 3.7: Totalization Table Registration
	Handbook for Electricity Metering, Edison Electric Institute, 1992

– End of Document –